

From the library of: Diamond Needle Corp

ARTS Import Error:

Application error: LZW minimum code size other than 8 bit not supported in GIF file 'E:\www\images\PartsBook\juki\LUH-526\0003.gif'

2. MAIN SHAFT & THREAD TAKE-UP COMPONENTS

上軸天秤関係

Ref. No.	Note 注記	Part No. 品番	Description	E. C. 変更年月	品名	Amt. Req. 個数
1		B1905-526-080	THREAD TAKE-UP LEVER ASM.		フックン クミ	1
2		B1905-526-0A0	THREAD TAKE-UP LEVER ASM.		フックン クミ	(1)
3		CQ-2520000-00	OIL WICK		油シ	(0,1)
4		TA-0290301-M0	PLUG 2,9X3,2 L=3,0		トメシ 2,9X3,2 L=3	(1)
5		B1906-526-0A0	THREAD TAKE-UP LEVER PIN ASM.		フックン フックン クミ	(1)
6		CQ-2520000-00	OIL WICK		油シ	(0,1)
7		B1907-526-0A0	THRUST PIN		フックン スライトシク クミ	(1)
8		CQ-2020000-00	OIL WICK		油シ	(0,1)
9		SS-8151150-SP	SCREW 15/64-28 L=11,0		ワシラシ 15/64-28 L=11	1
10		B1408-526-000	NEEDLE BAR CRANK ROD		ハリシ - クランクロッド	1
11		B1210-526-0A0	NEEDLE BAR CRANK PIN ASM.		ハリシ - クランクピン フ	1
12		CQ-2020000-00	OIL WICK		油シ	(0,1)
13		B1206-051-000	COUNTERWEIGHT		ツライチ	1
14		SS-8680540-SP	SCREW 9/32-28 L= 4,5		トメシ 9/32-28 L= 4,5	1
15		SS-8680730-SP	SCREW 9/32-28 L= 7,0		トメシ 9/32-28 L= 7	2
16		SS-8681650-TP	SCREW (8) 9/32-28 L=16,0		トメシ 9/32-28 L=16	1
17		SS-7681750-TP	SCREW (9/32-28 L=16,5)		ワシラシ 9/32-28 L=16,5	1
18		B1207-051-0A0	PLUG SCREW		クワシク アワラトメシ クミ	1
19		CQ-2020000-00	OIL WICK		油シ	(1)
20		B1205-051-000	THRUST WASHER		クワシク ワシワシ フカシ	1
21		B1202-051-0A0	MAIN SHAFT BUSHING, UPPER		クワシク ワシワシ クミ	1
22		B1230-051-000	LEATHER PLUG		クワシク ワシワシ ショットメシ	(1)
23		CQ-2520000-00	OIL WICK		油シ	(0,1)
24		SS-8151150-SP	SCREW 15/64-28 L=13,0		トメシ 15/64-28 L=13	1
25		B1203-051-000	OIL FELT		クワシク ワシワシ ワシ	1
26		D1450-055-8A0	TOP FEED CAM ASM.		クワシク カム クミ	1
27		SS-8660530-TP	SCREW 1/4-40 L= 4,5		トメシ 1/4-40 L= 4,5	(1)
28		SS-8660970-TP	SCREW 1/4-40 L= 8,5		トメシ 1/4-40 L= 8,5	(1)
29		B1220-562-0A0	STITCH GRADUATOR ASM.		オリ メリイタ クミ	1
30		SS-8151230-SP	SCREW 15/64-28 L=12,0		トメシ 15/64-28 L=12	(2)
31		B1214-019-000	SPROCKET RING		スワロケツト リング	2
32		B1302-051-000	SPROCKET WHEEL, UPPER		ウエ スワロケツト	1
33		SS-8681650-TP	SCREW (8) 9/32-28 L=16,0		トメシ 9/32-28 L=16	1
34		SS-7681750-TP	SCREW (9/32-28 L=16,5)		ワシラシ 9/32-28 L=16,5	1
35		B1201-055-800	MAIN SHAFT		クワシク	1
36		B1233-012-000	END SCREW		ハシメクシ 27 シヤクシ	1
37		SS-8152030-SP	SCREW 15/64-28 L=20,0		トメシ 15/64-28 L=20	1
38		SS-8151780-SP	SCREW 15/64-28 L=17,0		トメシ 15/64-28 L=17	1
39		B1227-520-000	HAND WHEEL		ハシメクシ	1
40		B1216-051-0A0	MAIN SHAFT BUSHING ASM, (REAR)		クワシク シロメシ (1) クミ	1
41		B1216-051-000	MAIN SHAFT BUSHING (1), REAR		クワシク シロメシ (1)	(1)
42		B1217-051-0A0	MAIN SHAFT REAR BUSHING (2) ASM.		クワシク シロメシ 2 クミ	(1)
43		SS-8150710-SP	SCREW 15/64-28 L= 7,0		トメシ 15/64-28 L= 7	(2)
44		B1219-051-000	MAIN SHAFT REAR BUSHING		ハシメクシ	(1)
45		B1218-051-000	REAR BEARING RETAINING COLLAR		クワシク シロハシメクシ トメ	(1)
46		SS-8151150-SP	SCREW 15/64-28 L=13,0		トメシ 15/64-28 L=13	1
47		B1301-051-000	TIMING BELT		タイミンクシ ハシ	1
48		B1303-055-AA0	SPROCKET WHEEL LOWER ASM,		ウエ スワロケツト アシメクシ	1
49		B1214-019-000	SPROCKET RING		スワロケツト リング	(1)
50		B1303-055-A00	SPROCKET WHEEL, LOWER		ウエ スワロケツト	(1)
51		SS-8090410-SP	SCREW 9/64-40 L= 3,5		トメシ 9/64-40 L= 3,5	(1)
52		B1310-055-000	SAFETY CLUTCH SMALL LINK		アシメクシ シヨ=リク	(1)
53		B1314-055-000	SAFETY CLUTCH SMALL LINK PIN		アシメクシ シヨ=リク ピン	(1)
54		B1307-055-000	SAFETY CLUTCH HOOK		アシメクシ ツメ	(1)
55		B1305-055-000-A	SAFETY CLUTCH SPRING		アシメクシ ハシ	(1)
56		SD-0640322-TP	HINGE SCREW D= 6,35 H= 3,2		クワシク D= 6,35 H= 3,2	(1)
57		B1309-055-000	SAFETY CLUTCH COUNTER-HOOK SPRING		アシメクシ キヤクツメ ハシ	(1)
58		B1308-055-000	SAFETY CLUTCH COUNTER-HOOK		アシメクシ キヤク ツメ	(1)
59		B1311-055-000	SAFETY CLUTCH BODY		アシメクシ クワ	(1)
60		SS-7661110-TM	SCREW 1/4-40 L=11,0		ワシラシ 1/4-40 L=11,0	(2)

From the library of: Diamond Needle Corp

3. ORGANIZED SPLIT NEEDLE BAR COMPONENTS

片針停止裝置圖

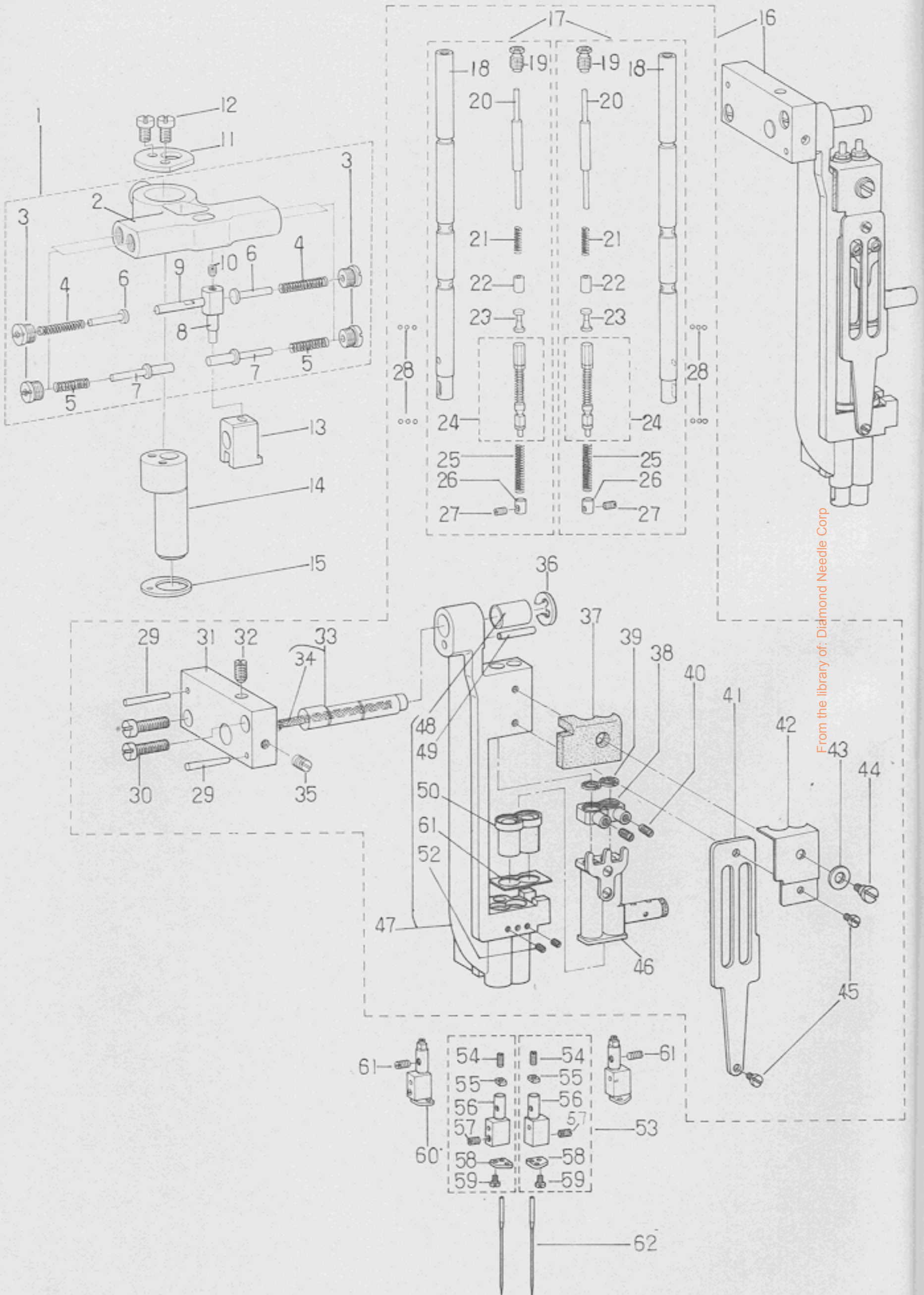

From the library of: Diamond Needle Corp

Ref. No.	Note 注記	Part No. 品番	Description	E. C. 変更年月	品名	Amt. Req. 個数
1		B1434-526-0A0	REPOSITIONING BASE ASM.		ハリチ-シ アンカクタイ クミ	1
2		B1434-526-000	REPOSITIONING BASE		ハリチ-シ アンカクタイ	(1)
3		B1438-526-000	PLUG SCREW		アツアイシク フタネシ	(4)
4		B1437-526-00A	SPRING L=21.7		カインヨハニ L=21.7	(2)
5		B1437-526-000	SPRING L=19.3		アツアイシクハニ L=19.3	(2)
6		B1435-526-000	GUIDE STUD		ハリチ-シ アンカク アツアイシク	(2)
7		B1436-526-000	DRIVING GUIDE STUD		ハリチ-シ ヨ-ト-アツアイシク	(2)
8		B1431-526-000	SLIDE PIN		ハリチ-シ アンカク ヨ-ト-ヒシ	(2)
9		B1455-526-000	SLIDE BLOCK STUD		アンカク ヨ-ト-コマシク	(1)
10		SS-8090410-TP	SCREW (9/64-40 L=3.9)		トメネシ 9/64-40 L=3.9	(1)
11		B1439-526-000	COVER PLATE		アンカクタイ フタ	1
12		SS-7090620-TP	SCREW 9/64-40 L=6.1		マルヒラネシ 9/64-40 L=6.1	2
13		B1427-526-000	DRIVING BRACKET		ハリチ-シ アンカク ヨ-ト-クイ	1
14		B1503-526-000	PRESSER BAR BUSHING, UPPER		オグニシ-クワメタル	1
15		B1432-526-000	WASHER		ハリチ-シ アンカクタイ クマカ	1
16		B1421-526-0C0	NEEDLE BAR FRAME ASM.		ハリチ-シ ヨ-ト-クイ クミ	1
17		B1401-526-0A0	NEEDLE BAR ASM.		ハリチ-シ クミ	(2)
18		B1401-526-000	NEEDLE BAR		ハリチ-シ	(2)
19		B1404-526-000	PLUG SCREW		ハリチ-シ フタネシ	(2)
20		B1405-526-000	PRESS BAR		ハリチ-シ オシネシ	(2)
21		B1406-526-000	SPRING		ハリチ-シ オシネシ-スリ-フ	(2)
22		B1407-526-000	PRESS BAR ROD		ハリチ-シ オシネシ-スリ-フ	(2)
23		B1409-526-000	BALL SLIDE STUD		ハリチ-シ オシネシ-スリ-フ	(2)
24		B1412-526-0A0	ADJUSTING SLIDE STUD ASM.		ハリチ-シ オシネシ-スリ-フ	(2)
25		B1415-526-000	SPRING		ハリチ-シ オシネシ-スリ-フ	(2)
26		B1416-526-000	COLLAR		ハリチ-シ アツシクハニ	(2)
27		SS-8080660-TP	SCREW 1/8-44 L=5.5		ハニクワ	(2)
28		B1410-526-000	BALL		トメネシ 1/8-44 L=5.5	(2)
29		PT-0301800-S0	TAPERED PIN (3.0x18 3.0x18)		ハリチ-シ オシネシ	(12)
30		SS-7111310-TP	SCREW 11/64-40 L=12.8		ク-ハニシ 3.0x18	(2)
31		B1430-526-000	NEEDLE BAR FRAME SHAFT BASE		マルヒラネシ 11/64-40 L=12.8	(2)
32		SS-8110750-SP	SCREW 11/64-40 L=6.5		ハリチ-シ ヨ-ト-クイ クミ	(1)
33		B1429-526-0A0	NEEDLE BAR FRAME SHAFT ASM.		トメネシ 11/64-40 L=6.5	(1)
34		CQ-2520000-00	OIL WICK		ハリチ-シ ヨ-ト-クイ クミ	(1)
35		SS-8111610-SP	SCREW 11/64-40 L=15.5		トメネシ 11/64-40 L=15.5	(1)
36		RE-0700000-K0	SNAP RING 7.0		エカク トメク 7	(1)
37		B1451-526-000	OIL FELT		ハリチ-シ *2-27ニト	(1)
38		B1418-526-000	NEEDLE BAR FIXED PIN		ハリチ-シ *2-27ニト	(1)
39		B1417-526-000	HALF RING		ハリチ-シ *2-27ニト	(2)
40		SS-8090710-SP	SCREW 9/64-40 L=7.0		ハリチ-シ *2-27ニト	(4)
41		B1423-526-000	NEEDLE BAR GUIDE PLATE		トメネシ 9/64-40 L=7	(2)
42		B1450-526-000	OIL FELT PRESSER		ハリチ-シ アツシク	(1)
43		WP-0480856-SP	WASHER 4.8x8.4x0.8		ハリチ-シ *2-27ニト オグニ	(1)
44		SD-0450401-SP	HINGE SCREW D=4.5 H=4.0		ヒラネシ 4.8x8.4x0.8	(1)
45		SS-6090510-SP	SCREW 9/64-40 L=5.0		タメネシ D=4.5 H=4	(1)
46		B1420-526-0A0	NEEDLE BAR BRACKET ASM.		ヒラネシ 9/64-40 L=5	(2)
47		B1421-526-0B0	NEEDLE BAR FRAME ASM.		ハリチ-シ *2-27ニト	(1)
48		B1452-526-000	NEEDLE BAR FRAME BUSHING		ハリチ-シ ヨ-ト-クイ クミ	(1)
49		PS-0400222-K0	SPRING PIN		ハリチ-シ ヨ-ト-クイ クミ	(1)
50		B1501-526-000	NEEDLE BAR LOWER BUSHING		ハリチ-シ ヨ-ト-クイ クミ	(1)
51		B1453-526-00B	THRUST PLATE T=0.6		ハリチ-シ ヨ-ト-クイ クミ	(1)
52		SS-8080310-TP	SCREW 1/8-44 L=2.8		ハリチ-シ ヨ-ト-クイ クミ	(1)
53		B1402-526-HAR	NEEDLE CLAMP 5/16 ASM., RIGHT		ハリチ-シ ヨ-ト-クイ クミ	(1)
54		SS-8080610-SP	SCREW 1/8-44 L=5.5		ハリチ-シ ヨ-ト-クイ クミ	1
55		B1424-526-000	NUT		ハリチ-シ ヨ-ト-クイ クミ	(2)
56		B1402-526-H00	NEEDLE CLAMP 5/16		ハリチ-シ ヨ-ト-クイ クミ	(2)
57		SS-8080660-TP	SCREW 1/8-44 L=5.5		ハリチ-シ ヨ-ト-クイ クミ	(2)
58		B1403-526-000	THREAD GUIDE		ハリチ-シ ヨ-ト-クイ クミ	(2)
59		SS-5060310-SP	SCREW 3/32-56 L=2.8		ハリチ-シ ヨ-ト-クイ クミ	(2)
60		B1402-526-HAL	NEEDLE CLAMP 5/16 ASM., LEFT		ハリチ-シ ヨ-ト-クイ クミ	(2)
61		SS-8080650-TP	SCREW 1/8-44 L=6		ハリチ-シ ヨ-ト-クイ クミ	1
62		MDP-170B1800	NEEDLE DPX17 #18		ハリチ-シ ヨ-ト-クイ クミ	2

From the library of: Diamond Needle Corp

4. FEED ROCK SHAFT COMPONENTS

水平送り軸関係

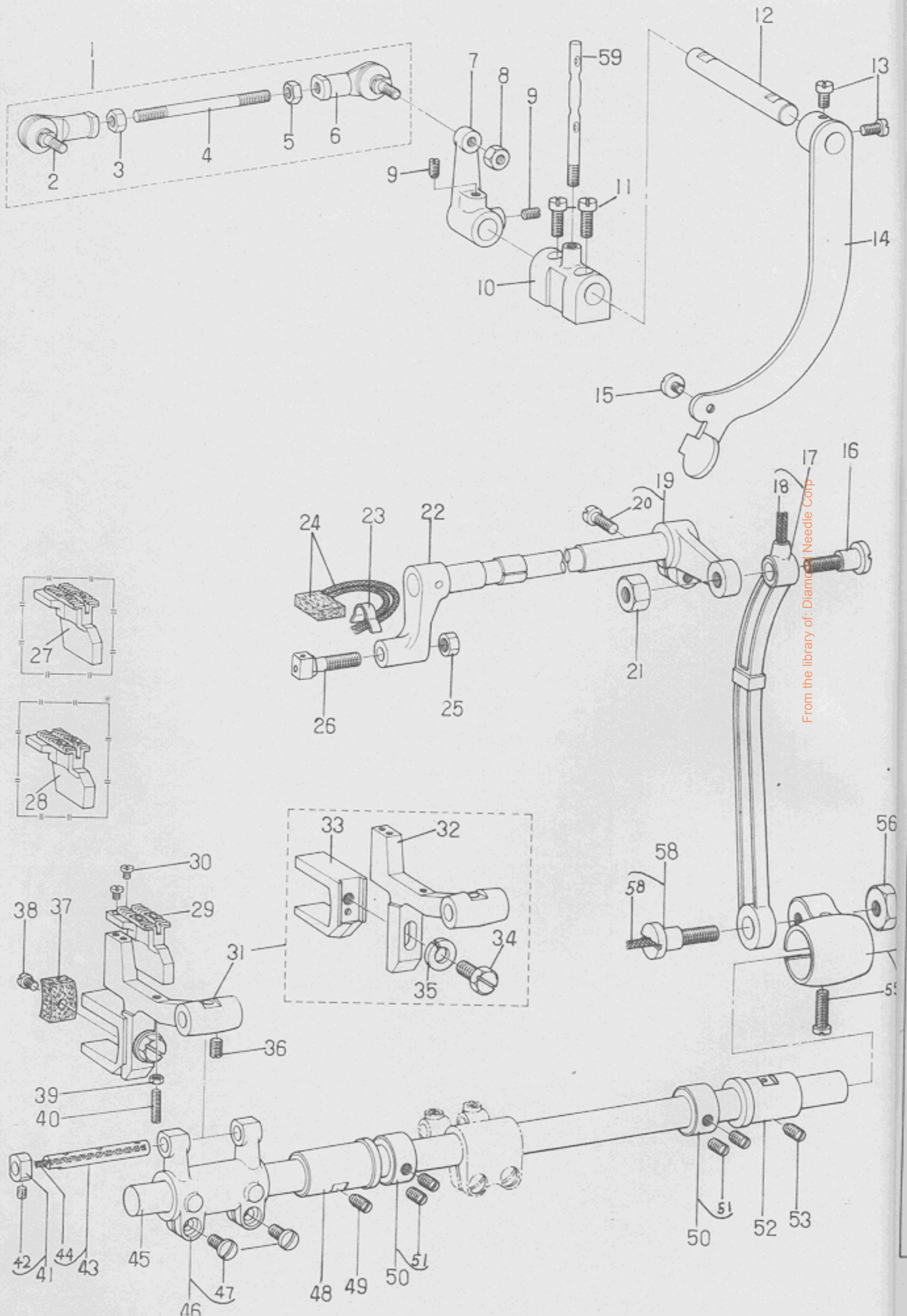

From the library of: Diamond Needle Corp

4. NEEDLE BAR & FEED ROCK SHAFT COMPONENTS

針棒水平軸関係

Ref. No.	Note	Part No. 品番	Description	E. C. 変更年月	品名	Amt. Req. 個数
1		B1440-526-0A0	BALL JOINT ASM.		ボールジョイント クミ	1
2		B1440-526-000	BALL JOINT (LEFT)		ボールジョイント ヒダリ	(1)
3		NM-6050550-SP	NUT M6		6カクナット M6	(1)
4		B1441-526-000	ADJUSTING SHAFT ROD		チヨセツシク ロツト	(1)
5		NM-6050001-SP	NUT M5		6カクナツト	(1)
6		B1442-526-000	BALL JOINT (RIGHT)		ボールジョイント ミキ	(1)
7		B1443-526-000	REPOSITIONING ARM		ハリチシ アツカツチ	1
8		NM-6050001-SP	NUT M5		6カクナツト	1
9		SS-6111010-SP	SCREW 11/64-40 L= 9,5		ヒラヌシ 11/64-40 L= 9,5	2
10		B1444-526-000	REPOSITIONING LEVER SHAFT BASE		アツカツ レバシキクツチ	1
11		SS-6121210-SP	SCREW 3/16-28 L=12,0		ヒラヌシ 3/16-28 L=12	2
12		B1447-526-000	REPOSITIONING LEVER SHAFT		アツカツ レバシキク	1
13		SS-7110740-TP	SCREW 11/64-40 L= 7,0		マルヒラヌシ 11/64-40 L= 7	2
14		B1445-526-0A0	REPOSITIONING LEVER ASM.		アツカツ レバシキク	1
15		SS-61110430-TP	SCREW 11/64-40 L= 4,0		ヒラヌシ 11/64-40 L= 4	1
16		SD-0790801-SP	HINGE SCREW D= 7,94 H= 8,0		タツシキ D= 7,94 H= 8	1
17		B1434-051-0A0	NEEDLE BAR FRAME ROD ASM.		ハリチシ ヨトシキクツチ クミ	1
18		CQ-2020000-00	OIL WICK		ヒシ	(0,1)
19		B1431-520-0A0	ROCK SHAFT REAR CRANK		ハリチシ ヨトシキクツチ クミ	1
20		SS-6151440-SP	SCREW 15/64-28 L=14,0		ヒラヌシ 15/64-28 L=14	(1)
21		NS-6160520-SP	NUT 1/4-24		6カクナツト 1/4-24	1
22		B1428-526-0A0	ROCK SHAFT FRONT CRANK ASM.		ハリチシ ヨトシキクツチ クミ	1
23		B1437-051-000	OIL WICK RETAINER		ヨトシキ シキツチ ヒシ	1
24		B1438-051-0A0	OIL WICK		ヨトシキ シキツチ ヒシ	1
25		NS-6620310-SP	NUT 3/16-32		6カクナツト 3/16-32	1
26		B1426-526-0A0	SLIDE BLOCK STUD ASM.		ハリチシ ヨトシキクツチ クミ	1
27	◇01	B1613-521-H00	FEED DOG 5/16		オクリハ 5/16 2,6x7	1
28	◇01	B1613-521-H0B	FEED DOG 5/16		オクリハ 5/16 2,6x7	1
29		B1613-521-H0A	FEED DOG 5/16		オクリハ 5/16 2,6x5	1
30		SS-6580752-TP	SCREW 1/8-40 L=7,0		6カクナツト 1/8-40 L=7	2
31		B1602-521-0A0	FEED BAR ASM.		オクリチシ クミ	1
32		B1602-521-000	FEED BAR		オクリチシ	(1)
33		B1604-051-000	FEED BAR SLIDE FORK		オクリチシ フタマタ	(1)
34		SS-9151440-CP	BOLT (15/64-28 L=14,0)		6カクナツト 15/64-28 L=14	(1)
35		WS-0651510-KP	SPRING WASHER 6,5X12,5X1,5		ハネワシカネ 6,5X12,5X1,5	(1)
36		SS-8620610-SP	SCREW 3/16-32 L= 6,0		ヒラヌシ 3/16-32 L= 6	1
37		B1605-051-000	OIL SUPPLY FELT		オクリチシ フタマタ アツカツチ	1
38		SS-5080710-SP	SCREW 1/8-44 L= 6,5		ヒラヌシ 1/8-44 L= 6,5	1
39		NS-6080210-SP	NUT 1/8-44		6カクナツト 1/8-44	1
40		SS-8081050-TH	SCREW 1/8-55 L=10,0		ヒラヌシ 1/8-55 L=10	1
41		CS-0640660-SH	THRUST COLLAR ASM. D=6,35		スラストワシ D= 6,35 クミ	1
42		SS-8090410-TP	SCREW (9/64-40 L=3,9)		ヒラヌシ 9/64-40 L= 3,9	(1)
43		B1604-012-0A0	FEED BAR SHAFT ASM.		オクリチシ シキク	1
44		CQ-2520000-00	OIL WICK		ヒシ	(0,1)
45		B1601-521-000	FEED ROCK SHAFT		スイハイ オクリチシ	1
46		B1603-521-0A0	FEED ROCKER ARM ASM.		スイハイオクリ チヨセツツチ クミ	1
47		SS-7111310-TP	SCREW 11/64-40 L=12,8		マルヒラヌシ 11/64-40 L=12,8	(2)
48		B1607-051-000	FEED ROCK SHAFT BUSHING, FRONT		スイハイ オクリチシ マシ	1
49		SS-8151150-SP	SCREW 15/64-28 L=10,5		ヒラヌシ 15/64-28 L=10,5	1
50		CS-1401010-SC	THRUST COLLAR ASM.		スラストワシ D=14,0 W=10 クミ	2
51		SS-8150410-SP	SCREW 15/64-28 L= 4,0		ヒラヌシ 15/64-28 L= 4	(4)
52		B1609-051-000	FEED ROCK SHAFT BUSHING, REAR		スイハイ オクリチシ クシロマシ	1
53		SS-8152030-SP	SCREW 15/64-28 L=20,0		ヒラヌシ 15/64-28 L=20	1
54		B1435-051-0A0	DRIVING ROD CRANK		ハリチシ ヨトシキクツチ クミ	1
55		SS-6151920-SP	SCREW 15/64-28 L=19,0		ヒラヌシ 15/64-28 L=19	(1)
56		NS-6700420-SP	NUT 5/16-24		6カクナツト 5/16-24	1
57		SD-095080A-SP	HINGE SCREW ASM.		タツシキ クミ	1
58		CQ-2020000-00	OIL WICK		ヒシ	(0,1)
59		B1114-051-000	NEEDLE THREAD GUIDE PIN		イトアツナイボ	1

Note (注記) ◇01 -- Special order part 特別注文部品

From the library of: Diamond Needle Corp

5. PRESSER BAR & WALKING FOOT COMPONENTS

押工棒, 上送り関

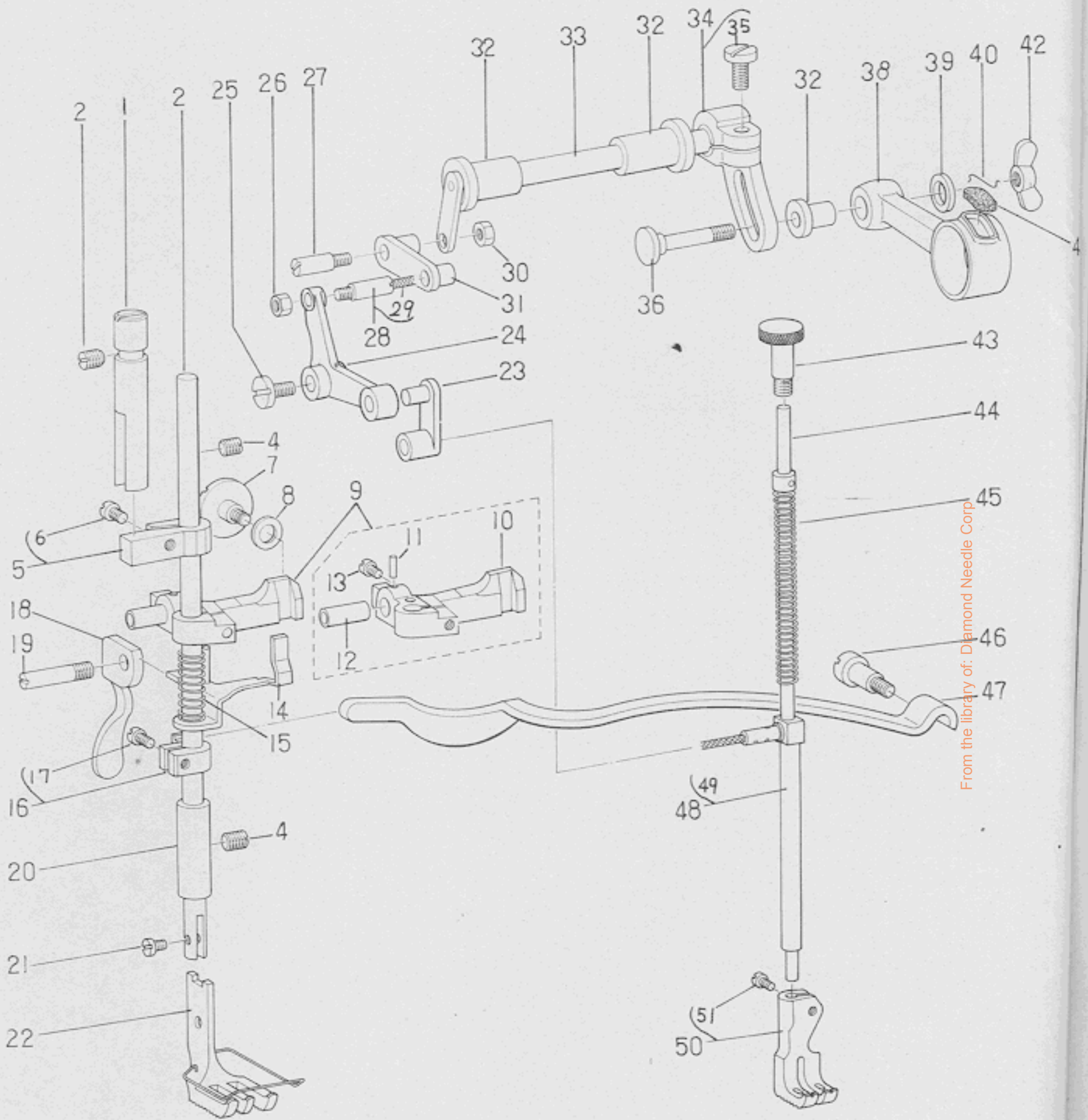

5. PRESSER BAR & WALKING FOOT COMPONENTS

押工棒上送り関係

Ref. No.	Note 注記	Part No. 品番	Description	E. C. 変更年月	品名	Amt. Req. 個数
1		B1502-051-000	PRESSER BAR GUIDE SLEEVE		オサエホ* アツタイツツ	1
2		SS-8151150-SP	SCREW 15/64-28 L=10,5		トメネジ* 15/64-28 L=10,5	1
3		B1501-040-000	PRESSER BAR		オサエホ*	1
4		SS-8151150-SP	SCREW 15/64-28 L=10,5		トメネジ* 15/64-28 L=10,5	2
5		B1504-051-0A0	PRESSER BAR GUIDE BRACKET ASM.		オサエホ* オサエホ* アツタイ クミ	1
6		SS-7090910-SP	SCREW 9/64-40 L= 8,5		マルヒラネジ* 9/64-40 L= 8,5	(1)
7		SD-0800481-SP	HINGE SCREW D= 8,00 H= 4,9		タ*ツネジ* D= 8 H= 4,9	1
8		WP-0651056-SD	WASHER 6,5X11,0X1,0		ヒラネジ* 6,5X11,0X1	1
9		B1460-053-0A0	PRESSER LIFTER LEVER ASM.		オサエホ* オサエホ* クミ	1
10		B1460-053-00A	HAND LIFTER MOUNTING BRACKET		オサエホ* オサエホ*	(1)
11		PT-0201200-S0	TAPERED PIN (2,0X12)		チ=11°ヒ*ン 2,0X12	(1)
12		B1460-053-00B	CONNECTING PIN		オサエホ* オサエホ* シ*ク	(1)
13		SS-7111310-SP	SCREW 11/64-40 L=12,8		マルヒラネジ* 11/64-40 L=12,8	(1)
14		B1461-521-0A0	THREAD RELEASE GUIDE ASM.		イトルメ ウケイタ クミ	1
15		B1462-053-000	THREAD RELEASE SPRING		イトルメ ウケイタ 11°ネ	1
16		B1507-051-0A0	PRESSER BAR GUIDE BRACKET ASM		オサエホ* オサエホ* クミ	1
17		SS-7090910-SP	SCREW 9/64-40 L= 8,5		マルヒラネジ* 9/64-40 L= 8,5	(1)
18		B1512-051-000	HAND LIFTER		オサエホ*	1
19		B1515-051-000	HAND LIFTER PIN		オサエホ* シ*ク	1
20		B1503-051-800	PRESSER BAR BUSHING, LOWER		オサエホ* シ*ク	1
21		SS-6090910-TP	SCREW 9/64-40 L= 9,0		オサエホ* シ*ク	1
22		B1525-520-HA0	PRESSER FOOT 5/16 ASM		オサエホ* シ*ク	1
23		B1465-526-000	WALKING BAR DRIVING LINK		ヒラネジ* 9/64-40 L= 9	1
24		B1459-526-00A	L SHAPED LINK		オサエ ホトアシ 5/16 クミ	1
25		SS-6111140-SP	SCREW 11/64-40 L=11,0		クワオクリ ヨ*ト*=リンク	1
26		NS-6110310-SP	NUT 11/64-40		クワオクリ ヨ*ト*	1
27		B1457-055-000	SCREW STUD		クワオクリ ヨ*ト*	1
28		B1459-053-0AB	L SHAPED LINK CONNECTING SCREW STUD ASM		クワオクリ ヨ*ト* リンク	1
29		CQ-2020000-00	OIL WICK		クワオクリ ヨ*ト* シ*ク クミ	1
30		NS-6660430-SP	NUT 1/4-40		クワオクリ ヨ*ト*	(0,1)
31		B1458-053-000	CONNECTING LINK		クワオクリ ヨ*ト*	1
32		B1455-053-000	BUSHING		クワオクリ ヨ*ト*	1
33		B1456-053-000	UPPER FEED DRIVING SHAFT		クワオクリ ヨ*ト*	2
34		D1454-055-BA0	UPPER FEED SPRING ROD ASM.		クワオクリ ヨ*ト*	1
35		SS-7161640-SP	SCREW 1/4-24 L=16,0		クワオクリ ヨ*ト*	1
36		D1456-055-800	HINGE SCREW		クワオクリ ヨ*ト*	1
37		D1455-055-800	CONNECTING STUD		クワオクリ ヨ*ト*	1
38		D1453-055-800	UPPER FEED DRIVING ROD		クワオクリ ヨ*ト*	1
39		D1457-055-800	WASHER		クワオクリ ヨ*ト*	1
40		B1213-012-000	FELT RETAINER		クワオクリ ヨ*ト*	1
41		B1702-012-000	OIL FELT		クワオクリ ヨ*ト*	1
42		D1458-055-800	WING SCREW		クワオクリ ヨ*ト*	1
43		B1469-526-000	PRESSER BAR ADJUSTING SCREW		クワオクリ ヨ*ト*	1
44		B1467-526-0A0	SPRING POLE ASM.		クワオクリ ヨ*ト*	1
45		B1468-053-000	WALKING BAR SPRING		クワオクリ ヨ*ト*	1
46		SD-0801601-SP	HINGE SCREW D= 8,00 H=16,0		クワオクリ ヨ*ト*	1
47		B1505-053-000	ADJUSTING PRATE SPRING		クワオクリ ヨ*ト*	1
48		B1466-053-0A0	WALKING BAR ASM		クワオクリ ヨ*ト*	1
49		CQ-2020000-00	OIL WICK		クワオクリ ヨ*ト*	1
50		B1470-521-HA0	WALKING FOOT 5/16 ASM		クワオクリ ヨ*ト*	(0,1)
51		SS-6110710-TP	SCREW 11/64-40 L= 6,5		クワオクリ ヨ*ト*	1

From the library of: Diamond Needle Corp

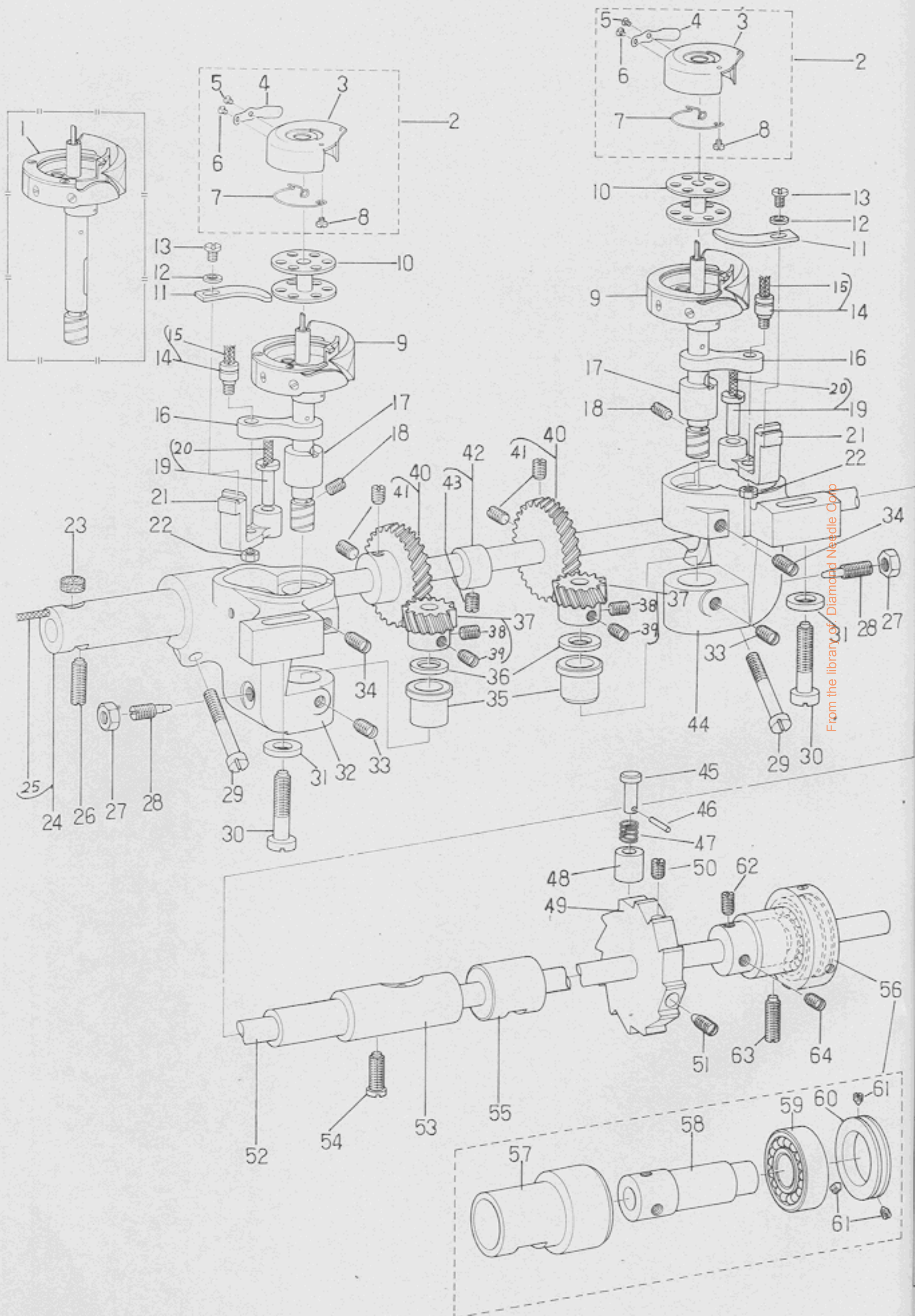

6. HOOK SHAFT & VERTICAL-AXIS HOOK COMPONENTS

下軸・水平釜関係

Ref. No.	Note 注記	Part No. 品番	Description	E. C. 変更年月	品名	Amt. Req. 個数
1	◇01	B1830-521-0A0	VERTICAL-AXIS SEWING HOOK (A) ASM.		スライカマ A クミ	2
2		B1837-526-0A0	BOBBIN CASE ASM		ボビンケース クミ	2
3		B1837-526-00A	BOBBIN CASE		ボビン ケース	(2)
4		B1837-526-00B	THREAD TENSION SPRING		イトチヨシ ハネ	(2)
5		SS-6560250-SH	SCREW 3/32-80 L=1.7		ヒラネジ 3/32-80 L=1.7	(2)
6		SS-2040210-SH	SCREW 1/16-80 L=1.6		マルワラネジ 1/16-80 L=1.6	(2)
7		B1837-526-00C	SPRING		シタイト キュ-ビウク ハネ	(2)
8		SS-6560150-SH	SCREW 3/32-80 L=1.3		ヒラネジ 3/32-80 L=1.3	(2)
9		B1830-521-0A0	VERTICAL-AXIS SEWING HOOK (B) ASM.		スライカマ B クミ	2
10		B9117-563-000	BOBBIN		ボビン	2
11		B1824-563-000	BOBBIN CASE OPENING LEVER		ナカカマ アコナイ	2
12		WP-0371016-SD	WASHER 3.7X8.0X1.0		ヒラワカネ 3.7X8.0X1	2
13		SS-6090620-SP	SCREW 9/64-40 L=6.0		ヒラネジ 9/64-40 L=6	2
14		B1821-051-0A0	CRANK SCREW STUD ASM.		ナカカマ アコナイ クランクボビン クミ	2
15		CQ-2020000-00	OIL WICK		オイル	(0,2)
16	B1820-051-000	BOBBIN CASE OPENING LEVER LINK		ナカカマ アコナイ リンク	2	
17	B1814-563-000	HOOK DRIVING SHAFT BUSHING, UPPER		カマシク カマダ	2	
18	SS-8151230-SP	SCREW 15/64-28 L=12.0		トメネジ 15/64-28 L=12	2	
19	B1823-051-0A0	BOBBIN CASE OPENING LEVER STUD ASM		ナカカマ アコナイシク クミ	2	
20	CQ-2020000-00	OIL WICK		オイル	(0,2)	
21	B1822-563-000	BOBBIN CASE OPENING LEVER CRANK		ナカカマ アコナイウチ	2	
22	NS-6110420-SP	NUT 11/64-40		6カクアツト 11/64-40	2	
23	B3542-581-000	OIL FELT		フェルト	1	
24	B1802-051-0A0	HOOK DRIVING SHAFT BUSHING, FRONT ASM		カマシク マイダ	1	
25	CQ-2020000-00	OIL WICK		オイル	(0,1)	
26	SS-8152030-SP	SCREW 15/64-28 L=20.0		トメネジ 15/64-28 L=20	1	
27	NS-6110420-SP	NUT 11/64-40		6カクアツト 11/64-40	2	
28	B1843-563-000	OIL ADJUSTING SCREW		カマ ユリヨ- チヨ-セツネジ	2	
29	SS-6153040-SP	SCREW 15/64-28 L=30.0		ヒラネジ 15/64-28 L=30	2	
30	SS-7762840-SP	SCREW 1/4-28 L=28.0		マルヒラネジ 1/4-28 L=28	2	
31	WP-0753016-SZ	WASHER 7.5x16.0x3.0		ヒラワカネ 7.5x16.0x3.0	2	
32	B1810-520-000	HOOK DRIVING SHAFT SADDLE, LEFT		カマシクタイ(ヒラネジ)	1	
33	SS-8150710-SP	SCREW 15/64-28 L=7.0		トメネジ 15/64-28 L=7	2	
34	SS-8151150-SP	SCREW 15/64-28 L=10.5		トメネジ 15/64-28 L=10.5	2	
35	B1815-563-000	HOOK DRIVING SHAFT BUSHING, LOWER		カマシク シタダ	2	
36	◇02	B1818-051-000	THRUST WASHER		ネジハク* マ スラストイ	2
37		B1817-051-0A0	HOOK DRIVING SHAFT GEAR, SMALL ASM		シヨ- ネジハク* マ クミ	2
38		SS-8660530-SP	SCREW		トメネジ	(2)
39		SS-8660670-SP	SCREW 1/4-40 L=6.1		トメネジ 1/4-40 L=6.1	(2)
40		B1816-521-0A0	HOOK DRIVING SHAFT GEAR, LARGE ASM		タイ ネジハク* マ クミ	2
41		SS-8660830-TP	SCREW 1/4-40 L=8.3		トメネジ 1/4-40 L=8.3	(4)
42		B1840-051-0A0	FEED DRIVING ECCENTRIC ASM.		シヨ-ウケ オクリカク クミ	1
43		SS-8150580-SP	SCREW 15/64-28 L=5.0		トメネジ 15/64-28 L=5	(1)
44		B1811-563-000	HOOK DRIVING SHAFT SADDLE RIGHT		カマシクタイ (ミキ)	1
45		B1312-055-000	SAFETY CLUTCH KNOB		アッセルソウチ オシボ* タン	1
46	PS-0200102-KH	SPRING PIN (2.0X10)		スプリング* ボン 2.0X10	1	
47	B1639-051-000	SPRING		オシボ* タン ハネ	1	
48	B1313-055-000	SAFETY CLUTCH KNOB SLEEVE		アッセルソウチ ボ* タン ツツ	1	
49	B1314-057-000	SAFETY CLUTCH RATCHET GEAR		アッセルソウチ ラチエツト * マ	1	
50	SS-8151780-SP	SCREW 15/64-28 L=17.0		トメネジ 15/64-28 L=17	1	
51	SS-8152080-SP	SCREW 15/64-28 L=19.5		トメネジ 15/64-28 L=19.5	1	
52	B1801-521-000	HOOK DRIVING SHAFT		カマシク	1	
53	B1804-051-000	HOOK DRIVING SHAFT BUSHING, INTERMEDIATE		カマシク ナカダ	1	
54	SS-6151920-SP	SCREW 15/64-28 L=19.0		ヒラネジ 15/64-28 L=19	1	
55	B1807-512-000	BUSHING (B), INTERMEDIATE		カマシク ナカダ B	1	
56	B1807-051-0A0	BUSHING (1) ASM, REAR		カマシク クシロダ	1	
57	B1807-051-000	HOOK DRIVING SHAFT BUSHING (1), REAR		カマシク クシロダ 1	(1)	
58	B1808-051-000	HOOK DRIVING SHAFT BUSHING (2), REAR		カマシク クシロダ 2	(1)	
59	B1219-051-000	MAIN SHAFT REAR BUSHING		ハ* アリク*	(1)	
60	B1809-051-000	BEARING RETAINING COLLAR		カマシク ハ* アリク* ト* マ	(1)	
61	SS-8090530-TP	SCREW 9/64-40 L=5.0		トメネジ 9/64-40 L=5	(3)	
62	SS-8150750-SP	SCREW 15/64-28 L=7.0		トメネジ 15/64-28 L=7	2	
63	SS-8152030-SP	SCREW 15/64-28 L=20.0		トメネジ 15/64-28 L=20	1	

Note (注記) ◇01 --- Special order part for LUH-526 (For extremely thick thread) LUH-526用特別注文部品(木糸用)

◇02 This is a selective part, so please consult us beforehand when placing your order.
この部品は選択部品でありますのでご注文の際はあらかじめ当方へお問い合わせ下さい。

From the library of: Diamond Needle Corp

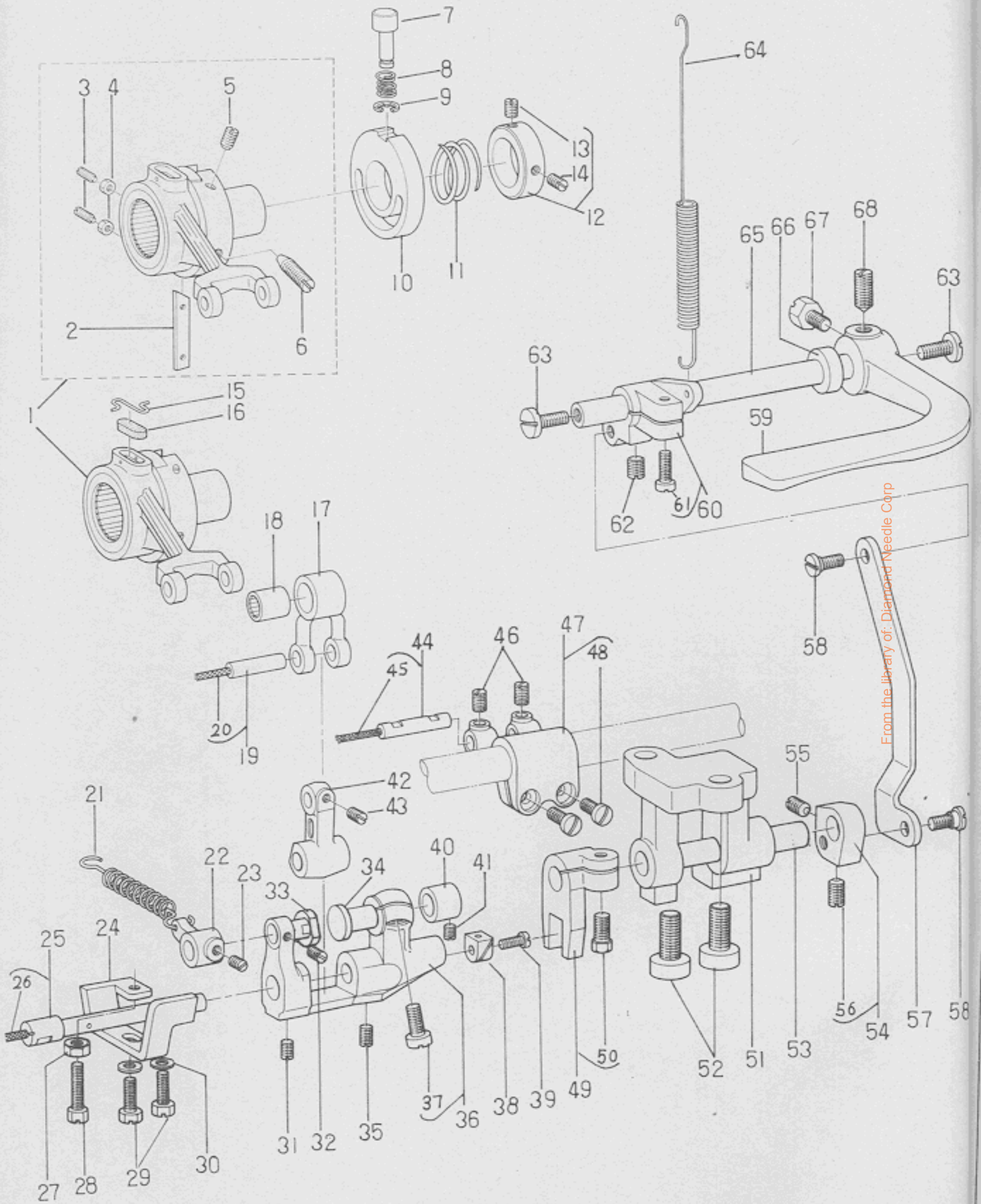

From the library of: Diamond Needle Corp

7. REVERSE FEED CONTROL LEVER COMPONENTS

送りレバー関係

Ref. No.	Note 注記	Part No. 品番	Description	E. C. 変更年月	品名	Amt. Req. 個数
1		B1614-521-0A0	CRANK CONNECTING ROD ASM.		オクリロツト* クミ	1
2		B1622-057-000	FRICTION PLATE		オクリ チヨ=セツ カミツリ	(1)
3		SS=8081050-TH	SCREW 1/8-55 L=10,0		トメネジ* 1/8 =44 L=10	(2)
4		NS=6080210-SP	NUT 1/8-44		6カクツツ 1/8=44	(2)
5		SS=8151780-SP	SCREW 15/64-28 L=17,0		トメネジ* 15/64=28 L=17	(1)
6		SS=8151770-SP	SCREW 15/64-28 L=17,0		トメネジ* 15/64=28 L=17	(1)
7		B1636-055-000	FEED ECCENTRIC ADJUSTING KNOB		オシネ* タン	1
8		B1639-051-000	SPRING		オシネ* タン ハネ	1
9		RE=0500000-K0	SNAP RING 5,0		エカ* タ トメワ 5	1
10		B1626-562-000	FEED ECCENTRIC GUIDE		オクリ チヨ=セツ アツナイカ	1
11		B1624-055-000	FEED ECCENTRIC BODY SPRING		オクリ チヨ=セツ ハネ	1
12		B1625-057-0A0	RETAINING COLLAR ASM.		オクリチヨ=セツタイ ハネツク クミ	1
13		SS=8110510-SP	SCREW 11/64-40 L= 5,0		トメネジ* 11/64=40 L= 5	(1)
14		SS=8110750-SP	SCREW 11/64-40 L= 6,5		トメネジ* 11/64=40 L= 6,5	(1)
15		B1213-012-000	FELT RETAINER		フエルト オウエ	1
16		B1702-012-000	OIL FELT		フエルト	1
17		B1647-562-000	FEED REGULATING FORK LINK		オクリ チヨ=セツ フタマツリツク	1
18		B1664-562-000	NEEDLE BEARING		フタマツリツク ミ=トハル シ* クツク	1
19		B1646-562-0A0	FEED REGULATING LINK PIN ASM.		オクリ チヨ=セツ リツク シ* ク クミ	1
20		CQ=2020000-00	OIL WICK		ビシ	(0,1)
21		B2007-232-000	TENSION SPRING		ビシ	(0,1)
22		B1647-122-000	SUSPENSION BRACKET (A)		ビツハ* リ ハネ	1
23		SS=8150710-SP	SCREW 15/64-28 L= 7,0		ビツハ* リ ハネカク A	1
24		B1667-521-000	FEED LIMITING PLATE		トメネジ* 15/64=28 L= 7	1
25		B1644-562-0A0	FEED REGULATING PIN ASM.		オクリ セイ* コシタ	1
26		CQ=2020000-00	OIL WICK		オクリ チヨ=セツ ヒ* コ クミ	1
27		NS=6110530-SP	NUT 11/64-40		ビシ	(0,1)
28		SS=9111820-SP	BOLT (11/64-40 L=18,0)		6カクツツ 11/64=40	1
29		SS=9121340-CP	BOLT (3/16-28 L=13,0)		6カクネ* ト 11/64=40 L=18	1
30		WP=0480856-SP	WASHER 4,8X8,4X0,8		6カクネ* ト 3/16=28 L=13	2
31		SS=8110750-SP	SCREW 11/64-40 L= 6,5		ヒラツキカネ 4,8X8,4X0,8	2
32		SS=8110520-TP	SCREW 11/64-40 L= 4,5		トメネジ* 11/64=40 L= 6,5	1
33		B1642-562-000	FEED REGULATING ARM PIN		トメネジ* 11/64=40 L= 4,5	1
34		B1641-562-000	FEED REGULATING ARM SHAFT		オクリ チヨ=セツツチ* ヒ* コ	1
35		SS=8110750-SP	SCREW 11/64-40 L= 6,5		オクリ チヨ=セツツチ* シ* ク	1
36		B1640-562-0A0	FEED REGULATING ARM ASM.		トメネジ* 11/64=40 L= 6,5	1
37		SS=7151210-SP	SCREW 15/64-28 L=12,0		オクリ チヨ=セツツチ* クミ	1
38		B1414-155-000	NEEDLE BAR CONNECTING SLIDE BLOCK		マルヒツツネ 15/64=28 L=12	(1)
39		SS=7090540-SP	SCREW		カクコ* マ	1
40		B1643-562-000	BUSHING, FOR ARM SHAFT		マルヒツツネ	1
41		SS=8110510-SP	SCREW 11/64-40 L= 5,0		オクリ チヨ=セツツチ* シ* ク マツル	1
42		B1645-562-000	FEED REGULATING LINK		トメネジ* 11/64=40 L= 5	1
43		SS=8110750-SP	SCREW 11/64-40 L= 6,5		オクリ チヨ=セツリツク	1
44		B1648-562-0A0	CONNECTING PIN ASM.		トメネジ* 11/64=40 L= 6,5	1
45		CQ=2020000-00	OIL WICK		スイ* イ オクリツチ* シ* ク クミ	1
46		SS=8110520-TP	SCREW 11/64-40 L= 4,5		ビシ	(0,1)
47		B1616-562-0A0	FEED ROCK SHAFT CRANK ASM.		トメネジ* 11/64=40 L= 4,5	2
48		SS=7111410-SP	SCREW 11/64-40 L=14,0		スイ* イ オクリツチ* クミ	1
49		B1651-562-0A0	FEED CHANGING FORK ASM.		マルヒツツネ 11/64=40 L=14	(2)
50		SS=9151630-CP	BOLT (15/64-28 L=15,5)		オクリ アツカシ* ク フタマツ クミ	1
51		B1652-521-000	FEED CHANGING SHAFT BASE (A)		6カクネ* ト 15/64=28 L=15,5	(1)
52		SM=6081542-CP	SCREW M8X1,25 L=15		オクリ アツカシ* クミ* イ A	1
53		B1653-521-000	FEED CHANGING SHAFT		6カクツツネ* ト M8 L=15	2
54		B1654-521-0A0	FEED CHANGING ARM ASM.		オクリ アツカシ* ク	1
55		SS=8151280-SP	SCREW 15/64-28 L=12,0		オクリ アツカシ* クミ	1
56		SS=8151150-SP	SCREW 15/64-28 L=10,5		トメネジ* 15/64=28 L=12	(1)
57		B1657-521-000	FEED REGULATING ROD		トメネジ* 15/64=28 L=10,5	1
58		SD=0640323-TP	HINGE SCREW D= 6,35 H= 3,2		オクリ チヨ=セツ ロツト*	1
59		B1624-555-000	REVERSE FEED CONTROL LEVER		ツ* コシタ D= 6,35 H= 3,2	2
60		B1658-521-0A0	TENSION SPRING REGULATING ARM ASM.		オクリ ハネ	1
61		SS=6121210-SP	SCREW 3/16-28 L=12,0		ビツハ* リ ハネカク チヨ=セツツチ* クミ	1
62		SS=8151280-SP	SCREW 15/64-28 L=12,0		ヒツツネ* 3/16=28 L=12	(1)
63		SS=7620750-SP	SCREW 3/16-32 L= 6,5		トメネジ* 15/64=28 L=12	1
64		B1666-521-000	TENSION SPRING (B)		マルヒツツネ* 3/16=32 L= 6,5	2
65		B1660-521-000	REVERSE FEED CONTROL LEVER SHAFT		ビツハ* リ ハネ B	1
66		B1662-562-000	COLLAR		オクリ チヨ=セツ リ ハネ* シ* ク	1
67		SS=9660940-SP	BOLT (1/4-40 L= 8,5)		オクリ ハネ* マカネ	1
68		SS=8660970-TP	SCREW 1/4-40 L= 8,5		6カクネ* ト 1/4=40 L=8,5	1
					トメネジ* 1/4=40 L= 8,5	1

From the library of Diamond Needle Corp

8. KNEE LIFTER & OIL RESERVOIR COMPONENTS

膝上げ油溜関

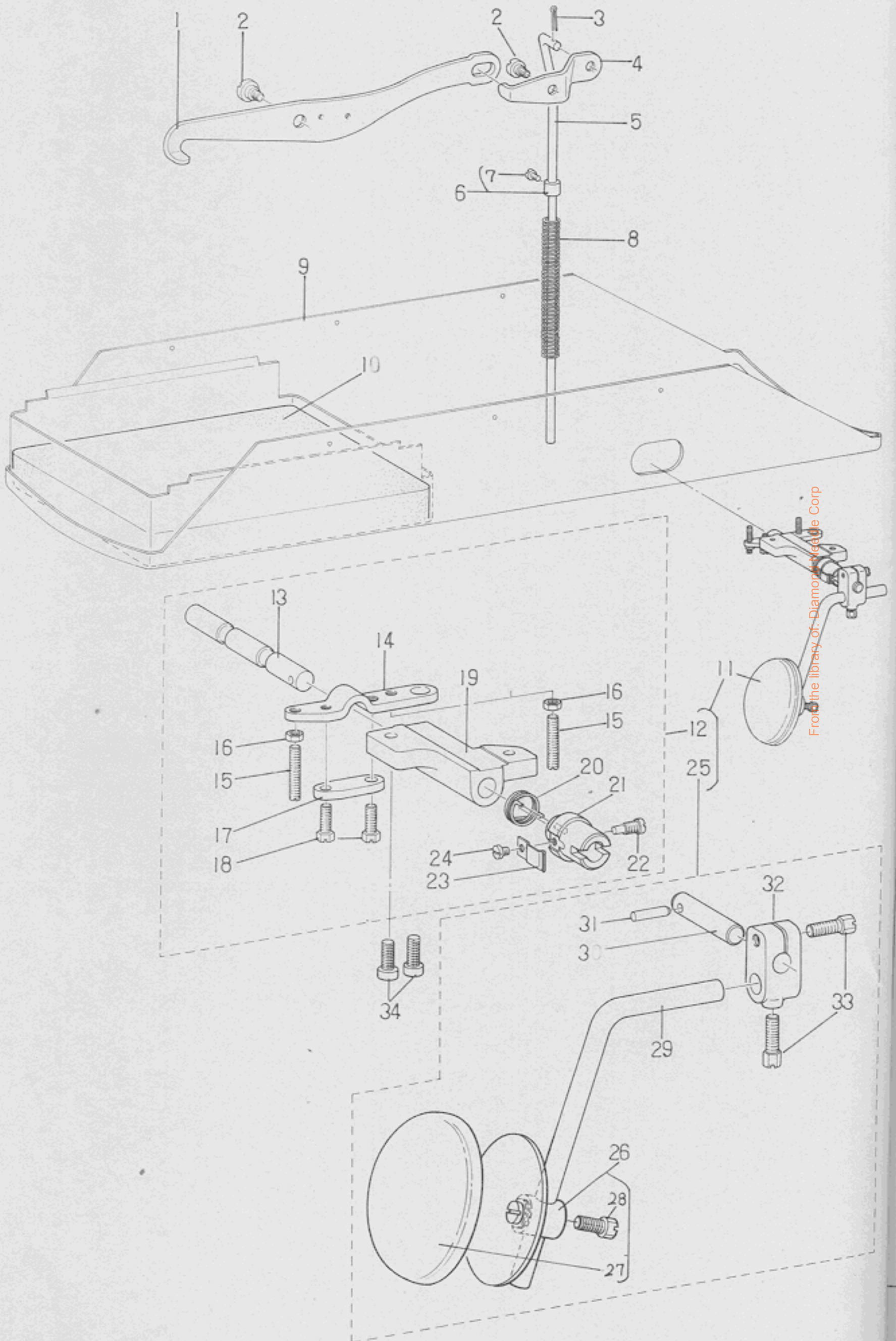

8. KNEE LIFTER & OIL RESERVOIR COMPONENTS

膝上げ油溜関係

Ref. No.	Note 注記	Part No. 品番	Description	E. C. 変更年月	品名	Amt. Req. 個数
1		B3409-053-000	KNEE LIFTER FRONT LEVER		ヒサアケ マイチ	1
2		SD-0790361-SP	HINGE SCREW D=7,94 H=3,6		クシメシ D=7,94 H=3,6	2
3		PD-0231100-0B	COTTER PIN 2,3X11		ワシピン 2,3X11	1
4		B3410-051-000	KNEE LIFTER REAR LEVER		ヒサアケ ウシロ テコ	1
5		B3413-521-000	REAR LIFTING BAR		ウシロツリ棒	1
6		CS-0510710-SC	THRUST COLLAR ASM. D=5,1 W=7		スラストワ D=5,1 W=7 7ミ	1
7		SS-7110540-SP	SCREW 11/64-40 L=5,0		マルヒラネシ 11/64-40 L=5	(1)
8		B3414-051-000	REAR LIFTING BAR SPRING		ウシロ ツリ棒 オシハネ	1
9		B1839-521-0A0	OIL RESERVOIR ASM.		アツラツマリ クミ	1
10		B1841-521-000	OIL DRIP FELT		カマシクタイ モルトフ レン	1
11		B3431-521-0C0	KNEE LIFTER ASM.		ヒサアケ ソチ クミ	1
12		B3431-521-0B0	KNEE DRIVING SHAFT BRACKET ASM.		ヒサアケ シクウチ クミ	(1)
13		B3426-521-000	KNEE PRESS ROD (A)		ヒサアチ ヨコシク A	(1)
14		B3425-521-000	ROTATING LEVER (B)		ヒサアケ カイチウチ B	(1)
15		SS-8153010-SP	SCREW 15/64-28 L=30,0		トメシ 15/64-28 L=30	(2)
16		NS-6150310-SP	NUT 15/64-28		6カクツト 15/64-28	(2)
17		B3424-521-000	ROTATING LEVER (A)		ヒサアケ カイチウチ A	(1)
18		SS-9151540-SP	BOLT (15/64-28 L=15,0)		6カクボルト 15/64-28 L=15	(2)
19		B3431-521-000	KNEE PRESS ROD ARM		ヒサアケ シクウチ	(1)
20		B3429-521-000	KNEE PRESS SPRING		ヒサアケ モトシハネ	(1)
21		B3430-521-000	KNEE PRESS JOINT		ヒサアケ ツキチ	(1)
22		SS-7151550-SP	SCREW		トメシ	(1)
23		B3428-521-000	PRESSER SPRING		ヒサアチシク オシハネ	(1)
24		SS-7090510-SP	SCREW 9/64-40 L=4,6		マルヒラネシ 9/64-40 L=4,6	(1)
25		B3427-521-0A0	KNEE PRESS ROD MOUNTING BRACKET ASM.		ヒサアチ タチシク トリツケウチ クミ	(1)
26		B3430-552-0A0	KNEE PRESS PLATE ASM.		ヒサアチイタ クミ	(1)
27		B3431-552-000-A	KNEE PRESS PLATE COVER		ヒサアチイタ カハ	(1)
28		SS-9661120-CP	BOLT (1/4-40 L=10,5)		6カクボルト 1/4-40 L=10,5	(1)
29		B3419-122-000	KNEE LIFTER PLATE ROD		ヒサアチ タチシク	(1)
30		B3420-521-000	KNEE PRESS ROD		ヒサアチ ヨコシク B	(1)
31		B3432-521-000	PIN		ヒサアチツキチ カシコウヒン	(1)
32		B3427-521-000	KNEE PRESS ROD MOUNTING BRACKET		ヒサアチ タチシク トリツケウチ	(1)
33		SS-9182010-SN	BOLT (9/32-20 L=20)		6カクボルト 9/32-20 L=20	(2)
34		SS-7151610-SP	SCREW 15/64-28 L=16		マルヒラネシ 15/64-28 L=16,	2

From the library of: Diamond Needle Corp

9. THREAD STAND UNIT COMPONENTS
(SPECIAL ORDER PARTS)

糸立装置関係
(特別注文部品)

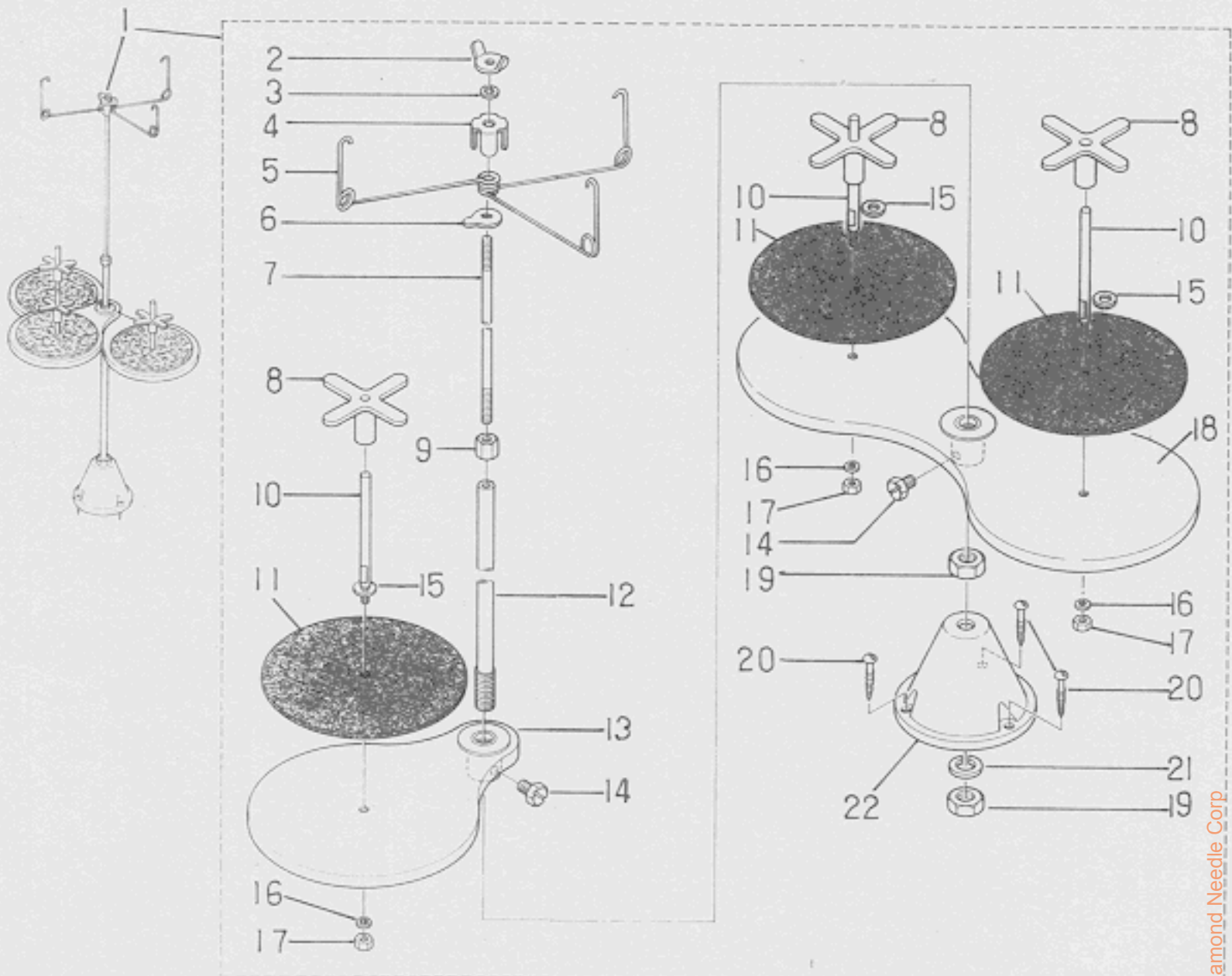

From the library of: Diamond Needle Corp.

9 THREAD STAND UNIT COMPONENTS (SPECIAL ORDER PARTS)				糸立装置関係		
Ref. No.	Note 注記	Part No. 品番	Description	E. C. 変更年月	品名	Amt. Req. 個数
1		B3301-051-0B0	THREAD STAND ASM.		イトダ ソーチ	1
2		B3310-012-000	POSITION CUP SET NUT		イトダ イアソナイ シメジ*	(1)
3		WS-0641560-KR	SPRING WASHER 6.4X11.9X1.5		ハ*スワ*カ*ズ 6.4X11.9X1.5	(1)
4		B3309-012-000	POSITION CUP		イトダ イアソナイ マクリト*メ	(1)
5		B3307-521-000	THREAD GUIDE		イトダ イアソナイ	(1)
6		B3308-012-000	ROD WASHER		イトダ イアソナイウケ	(1)
7		B3306-012-000	SPOOL ROD		イトダ ウエカン	(1)
8		B3312-012-000	SPOOL REST ROCK NUT		イトダ フレト*メ	(3)
9		NH-6061061-SE	NUT M-6		6カクナツ M6	(1)
10		B3305-012-000	SPOOL PIN		イトダ ウケホ*	(3)
11		B3311-012-000	SPOOL REST CUSHION		イトダ ウケサ*	(3)
12		B3302-012-000	SPOOL REST ROD		イトダ シメカン	(1)
13		B3303-372-0A0	SPOOL REST ASM.		イトダウケ クミ	(1)
14		SH-9061080-SE	BOLT		6カク*ナツ	(2)
15		WP-0560860-SE	WASHER 5.6X12X0.8		ヒラサ*カ*ズ 5.6X12X0.8	(3)
16		WS-0531060-KR	SPRING WASHER		ハ*スワ*カ*ズ	(3)
17		NS-6123881-SE	NUT (3/16-28)		6カクナツ 3/16-28	(3)
18		B3303-012-0A0	SPOOL REST ASM.		イトダウケ クミ	(1)
19		NH-6100663-SE	NUT M10		6カクナツ M10	(2)
20		SK-3452000-SE	WOOD SCREW		イトダダ*イ トメジ*	(3)
21		WS-1002560-KR	SPRING WASHER 10.0X18.0X2.5		ハ*スワ*カ*ズ 10.0X18.0X2.5	(1)
22		B3301-012-000	SPOOL STAND		イトダダ*イ	(1)

10. BELT COVER & THREAD WINDER COMPONENTS

ベルトカバー、糸巻装置関係

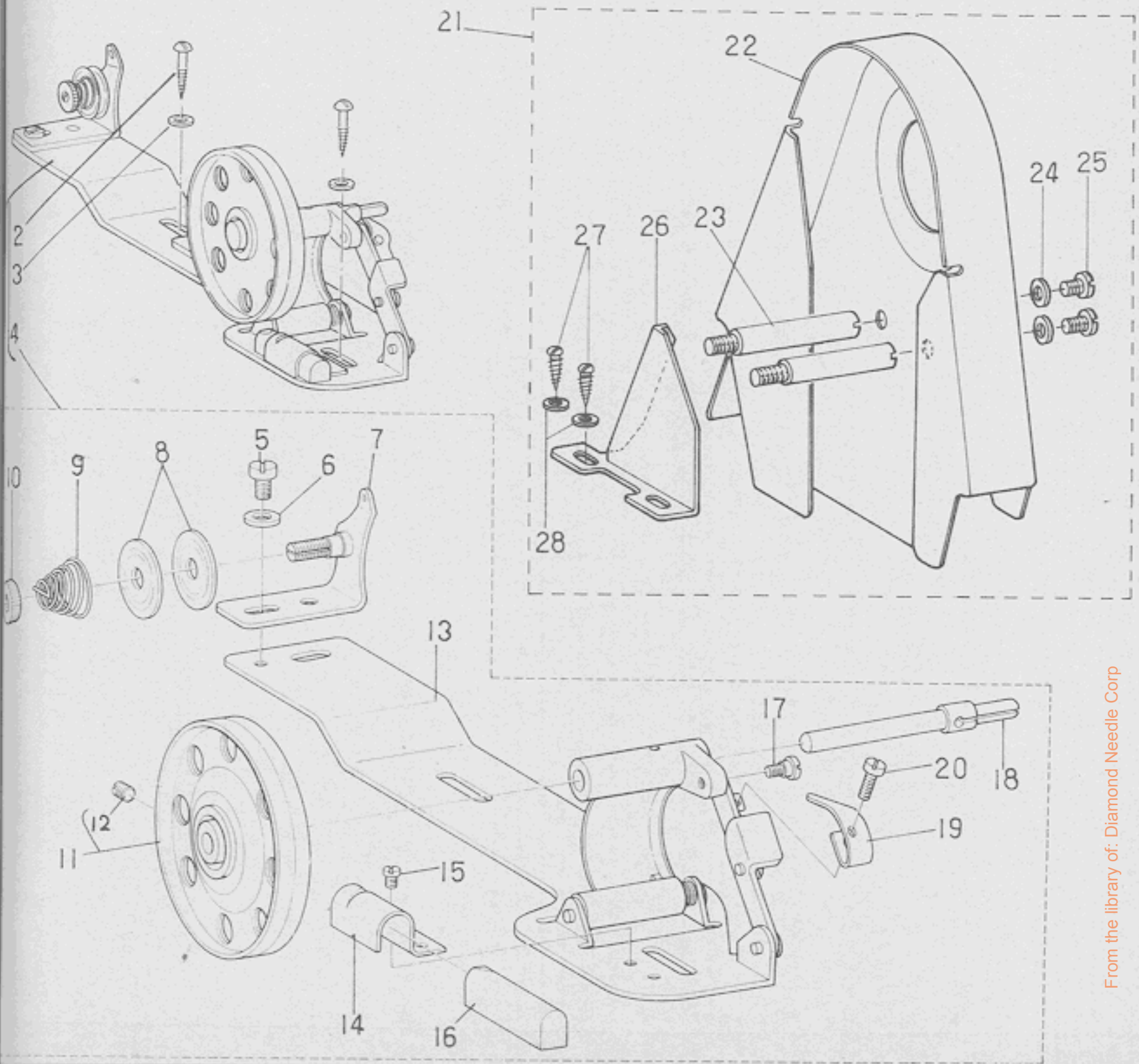









From the library of: Diamond Needle Corp

10		BELT COVER & THREAD WINDER COMPONENTS		ベルトカバー、糸巻装置関係		
Ref. No.	Note 注記	Part No. 品番	Description	E. C. 変更年月	品名	Amt. Req. 個数
1		B3201-012-0B0	THREAD WINDER ASM.		イトマキソーチ	1
2		SK-3482000-SC	WOOD SCREW		マシクネジ	(2)
3		WP-0501016-SC	WASHER 5.0X10.5X1.0		ヒラワカマ 5.0X10.5X1	(2)
4		B3201-012-0A0	BOBBIN WINDER (6) ASM.		イトマキソーチ	(1)
5		SS-7110820-SN	SCREW (11/64-40 L=7.5)		マシクネジ 11/64-40 L=7.5	(1)
6		WP-0501016-SC	WASHER 5.0X10.5X1.0		ヒラワカマ 5.0X10.5X1	(1)
7		B3223-012-0A0	TENSION BRACKET ASM.		イトマキ イトチヨウシキマソイ クミ	(1)
8		B3126-012-000	TENSION DISC		イトチヨウシ クラ	(2)
9		B3129-012-800	TENSION SPRING (8)		イトチヨウシ ハネ B	(1)
10		B3125-012-000	THREAD TENSION STUD NUT		イトチヨウシ ナット	(1)
11		B3214-012-0A0	BOBBIN WINDER WHEEL ASM.		イトマキクママ クミ	(1)
12		SS-8110510-SN	SCREW (11/64-40 L=5.0)		マシクネジ 11/64-40 L=5	(1)
13		B3204-012-0A0	THREAD WINDER BASE ASM.		イトマキソイ クミ	(1)
14		B3229-012-000	BRAKE CLAMP		セイトマキソイ クミ	(1)
15		SS-7110410-SN	SCREW 11/64-40 L=4.0		マシクネジ 11/64-40 L=4	(1)
16		B3228-012-000	BRAKE (RUBBER)		セイトマキソイ	(1)
17		SD-0490261-SP	HINGE SCREW D=4.90 H=2.6		クマシクネジ D=4.90 H=2.6	(1)
18		B3212-012-000	SPINDLE (6)		イトマキシク	(1)
19		B3217-012-000	STOP LATCH		ホシヒンソウ	(1)
20		SS-7081310-SN	SCREW (1/8-44 L=12.5)		マシクネジ 1/8-44 L=12.5	(1)
21		B8230-521-0A0	BELT COVER ASM.		イトマキカハマ クミ	1
22		B8230-521-00A	BELT COVER		イトマキカハマ	(1)
23		B8230-521-00B	BELT COVER SUPPORT STUD		イトマキカハマ ササヒ	(2)
24		WP-0650876-SD	WASHER 6.5X13.0X0.8		ヒラワカマ 6.5X13.0X0.8	(2)
25		SS-7150740-SP	SCREW 15/64-28 L=7.0		マシクネジ 15/64-28 L=7	(2)
26		B8230-521-00C	BELT COVER AUXILIARY PLATE		イトマキカハマ サシヨイ	(1)
27		SK-3482000-SC	WOOD SCREW		マシクネジ	(2)
28		WP-0501016-SC	WASHER 5.0X10.5X1.0		ヒラワカマ 5.0X10.5X1	(2)

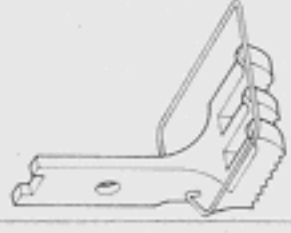
11. TABLE OF EXCHANGING GAUGE PARTS

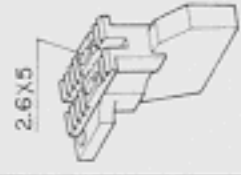
交換ギージ部品一覧表

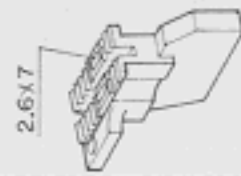
	A	B	C	D	E	F	G	H	I	J
										
Needle Gauge (2)	Throat Plate	Needle Clamp asm. Left	Needle Clamp asm. Right	Walking Foot asm.	Presser Foot asm.	Bed Slide, Left	Bed Slide, Right	Feed Dog	Feed Dog	Feed Dog
針幅	針板	針留(左)	針留(右)	押工中足(組)	押工升足(組)	滑り板(左)	滑り板(右)	送り歯	送り歯	送り歯
$\frac{3}{16}$ (4.8mm)	B1109-521-000	B1402-526-0AL	B1402-526-DAR	B1470-521-DA0	B1525-521-DA0	B1112-512-C00	B1113-512-C00	B1613-521-00A	B1613-521-00B	B1613-521-000
$\frac{1}{4}$ (6.4mm)	B1109-521-F00	B1402-526-FAL	B1402-526-FAR	B1470-521-FA0	B1525-520-FA0	B1112-512-E00	B1113-512-E00	B1613-521-F0A	B1613-521-F0B	B1613-521-F00
$\frac{3}{8}$ (9.5mm)	B1109-521-K00	B1402-526-KAL	B1402-526-KAR	B1470-521-KA0	B1525-520-KA0	B1112-512-F00	B1113-512-F00	B1613-521-K0A	B1613-521-K0B	B1613-521-K00
$\frac{1}{2}$ (12.7mm)	B1109-521-L00	B1402-526-LAL	B1402-526-LAR	B1470-521-LA0	B1525-521-LA0	B1112-512-H00	B1113-512-H00	B1613-521-L0A	B1613-521-L0B	B1613-521-L00
standard 標準	B1109-521-H00	B1402-526-HAL	B1402-526-HAR	B1470-521-HA0	B1525-520-HA0	B1112-512-D00	B1113-512-D00	B1613-521-H0A	B1613-521-H0B	B1613-521-H00
$\frac{5}{16}$ (7.9mm)										

NUMERICAL INDEX OF PARTS

索引

Part No. 品番	Page 頁	Item 項目	Ref. No.	Part No. 品番	Page 頁	Item 項目	Ref. No.	Part No. 品番	Page 頁	Item 項目	Ref. No.
EXCLUSIVE PARTS "B" 専用部品 "B"				B1405-526-000	06	03	20-	B1525-520-H00	10	05	22-
B1104-051-000	02	01	28-	B1406-526-000	06	03	21-	B1525-520-KA0	19	11	3-E
B1109-521-D00	19	11	1-A	B1407-526-000	06	03	22-	B1525-521-DA0	19	11	1-E
B1109-521-F00	19	11	2-A	B1408-526-000	04	02	10-	B1525-521-LA0	19	11	4-E
B1109-521-H00	02	01	27-	B1409-526-000	06	03	23-	B1601-521-000	08	04	45-
B1109-521-H00	19	11	5-A	B1412-526-000	06	03	24-	B1602-521-0A0	08	04	31-
B1109-521-K00	19	11	3-A	B1414-155-000	14	07	38-	B1602-521-000	08	04	32-
B1109-521-L00	19	11	4-A	B1415-526-000	06	03	25-	B1603-521-0A0	08	04	46-
B1110-051-0A0	02	01	39-	B1416-526-000	06	03	26-	B1604-012-0A0	08	04	43-
B1110-051-000	02	01	41-	B1417-526-000	06	03	39-	B1604-051-000	08	04	33-
B1111-051-0A0	02	01	40-	B1418-526-000	06	03	38	B1605-051-000	08	04	37-
B1112-512-C00	19	11	1-F	B1420-526-0A0	06	03	46	B1607-051-000	08	04	48-
B1112-512-C00	19	11	2-F	B1421-526-0B0	06	03	47	B1609-051-000	08	04	52-
B1112-512-D00	02	01	26-	B1421-526-0C0	06	03	16	B1613-521-D0A	19	11	1-H
B1112-512-D00	19	11	5-F	B1423-051-000	02	01	22	B1613-521-D0B	19	11	1-I
B1112-512-E00	19	11	3-F	B1423-526-000	06	03	41	B1613-521-D00	19	11	1-J
B1112-512-F00	19	11	4-F	B1424-526-000	06	03	55	B1613-521-F0A	19	11	2-H
B1113-512-C00	19	11	1-G	B1426-526-0A0	08	04	26	B1613-521-F0B	19	11	2-I
B1113-512-C00	19	11	2-G	B1427-526-000	06	03	13	B1613-521-F00	19	11	2-J
B1113-512-D00	02	01	32-	B1428-526-0A0	08	04	22	B1613-521-H0A	08	04	29-
B1113-512-D00	19	11	5-G	B1429-526-0A0	06	03	33	B1613-521-H0A	19	11	5-H
B1113-512-E00	19	11	3-G	B1430-526-000	06	03	31	B1613-521-H0B	08	04	28-
B1113-512-F00	19	11	4-G	B1431-520-0A0	08	04	19	B1613-521-H0B	19	11	5-I
B1128-541-000	02	01	15-	B1431-526-000	06	03	8	B1613-521-H00	08	04	27-
B1129-563-000	02	01	17-	B1432-526-000	06	03	15	B1613-521-H00	19	11	5-J
B1130-521-0A0	02	01	33-	B1434-051-0A0	08	04	17	B1613-521-K0A	19	11	3-H
B1130-521-000	02	01	34-	B1434-526-0A0	06	03	1	B1613-521-K0B	19	11	3-I
B1131-521-000	02	01	35-	B1434-526-000	06	03	2	B1613-521-K00	19	11	3-J
B1132-521-000	02	01	36-	B1435-051-0A0	08	04	54	B1613-521-L0A	19	11	4-H
B1140-526-000	02	01	4-	B1435-526-000	06	03	6	B1613-521-L0B	19	11	4-I
B1150-051-000	02	01	12-	B1436-526-000	06	03	7	B1613-521-L00	19	11	4-J
B1152-051-000	02	01	13-	B1437-051-000	08	04	23	B1614-521-0A0	14	07	1-
B1155-053-000	02	01	10-	B1437-526-00A	06	03	4	B1616-562-0A0	14	07	47-
B1157-009-0A0	02	01	31-	B1437-526-000	06	03	5	B1622-057-000	14	07	2-
B1158-526-000	02	01	7-	B1438-051-0A0	08	04	24	B1624-055-000	14	07	11-
B1202-051-0A0	04	02	21-	B1438-526-000	06	03	3	B1624-555-000	14	07	59-
B1203-051-000	04	02	25-	B1439-526-000	06	03	11	B1625-057-0A0	14	07	12-
B1205-051-000	04	02	20-	B1440-526-0A0	08	04	1	B1626-562-000	14	07	10-
B1206-051-000	04	02	13-	B1440-526-000	08	04	2	B1636-055-000	14	07	7-
B1207-051-0A0	04	02	18-	B1441-526-000	08	04	4	B1639-051-000	12	06	47-
B1210-526-0A0	04	02	11-	B1442-526-000	08	04	6	B1639-051-000	14	07	8-
B1213-012-000	10	05	40-	B1443-526-000	08	04	7	B1640-562-0A0	14	07	36-
B1213-012-000	14	07	15-	B1444-526-000	08	04	10	B1641-562-000	14	07	34-
B1214-019-000	04	02	31-	B1445-526-0A0	08	04	14	B1642-562-000	14	07	33-
B1214-019-000	04	02	49-	B1447-526-000	08	04	12	B1643-562-000	14	07	40-
B1216-051-0A0	04	02	40-	B1448-526-000	02	01	63	B1644-562-0A0	14	07	25-
B1216-051-000	04	02	41-	B1449-526-000	02	01	62	B1645-562-000	14	07	42-
B1217-051-0A0	04	02	42-	B1450-526-000	06	03	42	B1646-562-0A0	14	07	19-
B1218-051-000	04	02	45-	B1451-526-000	06	03	37	B1647-122-000	14	07	22-
B1219-051-000	04	02	44-	B1452-526-000	06	03	48	B1647-562-000	14	07	17-
B1219-051-000	12	06	59-	B1453-526-00B	06	03	51	B1648-562-0A0	14	07	44-
B1220-562-0A0	04	02	29-	B1455-053-000	10	05	32	B1651-562-0A0	14	07	49-
B1227-520-000	04	02	39-	B1455-526-000	06	03	9	B1652-521-000	14	07	51-
B1230-051-000	04	02	22-	B1456-053-000	10	05	33	B1653-521-000	14	07	53-
B1233-012-000	04	02	36-	B1457-055-000	10	05	27	B1654-521-0A0	14	07	54-
B1301-051-000	04	02	47-	B1458-053-000	10	05	31	B1657-521-000	14	07	57-
B1302-051-000	04	02	32-	B1459-053-00B	10	05	28-	B1658-521-0A0	14	07	60-
B1303-055-AA0	04	02	48-	B1459-526-00A	10	05	24-	B1660-521-000	14	07	65-
B1303-055-A00	04	02	50-	B1460-053-0A0	10	05	9-	B1662-562-000	14	07	66-
B1305-055-000-A	04	02	55-	B1460-053-00A	10	05	10-	B1664-562-000	14	07	18-
B1307-055-000	04	02	54-	B1460-053-00B	10	05	12-	B1666-521-000	14	07	64
B1308-055-000	04	02	58-	B1461-521-0A0	10	05	14-	B1667-521-000	14	07	24-
B1309-055-000	04	02	57-	B1462-053-000	10	05	15-	B1702-012-000	10	05	41-
B1310-055-000	04	02	52-	B1465-526-000	10	05	23-	B1702-012-000	14	07	16-
B1311-055-000	04	02	59-	B1466-053-000-A	10	05	48-	B1801-521-000	12	06	52
B1312-055-000	12	06	45-	B1467-526-0A0	10	05	44-	B1802-051-0A0	12	06	24
B1313-055-000	12	06	48-	B1468-053-000	10	05	45-	B1804-051-000	12	06	53
B1314-055-000	04	02	53-	B1469-526-000	10	05	43-	B1807-051-0A0	12	06	56
B1314-057-000	12	06	49-	B1470-521-DA0	19	11	1-D	B1807-051-000	12	06	57
B1401-526-0A0	06	03	17-	B1470-521-FA0	19	11	2-D	B1807-512-000	12	06	55
B1401-526-000	06	03	18-	B1470-521-HA0	19	11	5-D	B1808-051-000	12	06	58
B1402-526-DAL	19	11	1-B	B1470-521-H00	10	05	50-	B1809-051-000	12	06	60
B1402-526-DAR	19	11	1-C	B1470-521-KA0	19	11	3-D	B1810-520-000	12	06	32
B1402-526-FAL	19	11	2-B	B1470-521-L00	19	11	4-D	B1811-563-000	12	06	44
B1402-526-FAR	19	11	2-C	B1501-040-000	10	05	3-	B1814-563-000	12	06	17
B1402-526-HAL	06	03	60-	B1501-526-000	06	03	50-	B1815-563-000	12	06	35
B1402-526-HAL	19	11	5-B	B1502-051-000	10	05	1-	B1816-521-0A0	12	06	40
B1402-526-HAR	06	03	53-	B1503-051-800	10	05	20-	B1817-051-0A0	12	06	37
B1402-526-HAR	19	11	5-C	B1503-526-000	06	03	14-	B1818-051-000	12	06	36
B1402-526-H00	06	03	56-	B1504-051-0A0	10	05	5-	B1820-051-000	12	06	16
B1402-526-KAL	19	11	3-B	B1505-053-000	10	05	47-	B1821-051-0A0	12	06	14
B1402-526-KAR	19	11	3-C	B1507-051-0A0	10	05	16-	B1822-563-000	12	06	21
B1402-526-LAL	19	11	4-B	B1509-051-000	02	01	11-	B1823-051-0A0	12	06	19
B1402-526-LAR	19	11	4-C	B1512-051-000	10	05	18-	B1824-563-000	12	06	11
B1403-526-000	06	03	58-	B1515-051-000	10	05	19-	B1830-521-0A0	12	06	9
B1404-526-000	06	03	19-	B1525-520-FA0	19	11	2-E	B1830-521-HA0	14	07	64
				B1525-520-HA0	19	11	5-E	B1837-526-0A0	12	06	2

From the library of: Diamond Needle Corp

NUMERICAL INDEX OF PARTS

索引

Part No. 品番	Page 頁	Item 項目	Ref. No.	Part No. 品番	Page 頁	Item 項目	Ref. No.	Part No. 品番	Page 頁	Item 項目	Ref. No.
B1837-526-00A	12	06	3	OIL WICK		油心		SD-0790801-SP	08	04	16
B1837-526-00B	12	06	4					SD-0800481-SP	10	05	7
B1837-526-00C	12	06	7	CQ-2020000-00	04	02	8	SD-0801601-SP	10	05	46
B1838-521-000	02	01	43	CQ-2020000-00	04	02	12	SD-095080A-SP	08	04	57
B1839-521-0A0	16	08	9	CQ-2020000-00	04	02	19				
B1840-051-0A0	12	06	42	CQ-2020000-00	08	04	18	SCREW		ネジ	
B1841-521-000	16	08	10	CQ-2020000-00	08	04	58				
B1843-563-000	12	06	28	CQ-2020000-00	10	05	29	3K-3452000-SE	17	09	20
B1844-521-000	02	01	42	CQ-2020000-00	10	05	49	SK-3482000-SC	18	10	2
B1905-526-0A0	04	02	2	CQ-2020000-00	12	06	15	SK-3482000-SC	18	10	2
B1905-526-0B0	04	02	1	CQ-2020000-00	12	06	20	SK-3482000-SC	18	10	27
B1906-526-0A0	04	02	5	CQ-2020000-00	12	06	25	SM-6081542-CP	14	07	52
B1907-526-0A0	04	02	7	CQ-2020000-00	14	07	20	SM-9061080-SE	17	09	14
B2007-232-000	14	07	21	CQ-2020000-00	14	07	26	SS-2040210-SH	12	06	6
B3103-526-000	02	01	1	CQ-2020000-00	14	07	45	SS-2090710-SP	02	01	18
B3106-019-000	02	01	25	CQ-2520000-00	04	02	3	SS-2090710-SP	02	01	38
B3114-521-000	02	01	50	CQ-2520000-00	04	02	6	SS-2110920-TP	02	01	30
B3116-512-00B	02	01	57	CQ-2520000-00	04	02	23	SS-3090610-SP	02	01	5
B3120-125-000	02	01	56	CQ-2520000-00	06	03	34	SS-5060310-SP	06	03	59
B3121-526-0A0	02	01	48	CQ-2520000-00	08	04	44	SS-5080710-SP	08	04	38
B3121-526-0B0	02	01	45	THRUST COLLAR		スラストカラー		SS-6081210-SP	02	01	60
B3122-521-000	02	01	68					SS-6090510-SP	06	03	45
B3123-526-000	02	01	65	CS-0510710-SC	16	08	6	SS-6090620-SP	12	06	13
B3125-012-000	02	01	58	CS-0640660-SH	08	04	41	SS-6090630-SP	02	01	29
B3125-012-000	18	10	10	CS-1401010-SC	08	04	50	SS-6090910-TP	10	05	21
B3126-012-000	18	10	8	EXCLUSIVE PARTS "D"		専用部品 "D"		SS-6110430-TP	08	04	15
B3126-051-000	02	01	53					SS-6110610-TP	02	01	44
B3127-051-000	02	01	51	D1201-055-B00	04	02	35	SS-6110710-TP	10	05	51
B3127-512-000	02	01	52	D1450-055-BA0	04	02	26	SS-6111010-SP	08	04	9
B3128-526-000	02	01	66	D1453-055-B00	10	05	38	SS-6111140-SP	10	05	25
B3129-012-B00	18	10	9	D1454-055-BA0	10	05	34	SS-6121210-SP	08	04	11
B3129-526-000	02	01	55	D1455-055-B00	10	05	37	SS-6121210-SP	14	07	61
B3132-051-000	02	01	54	D1456-055-B00	10	05	36	SS-6151440-SP	08	04	20
B3134-520-000	02	01	46	D1457-055-B00	10	05	39	SS-6151920-SP	08	04	55
B3137-512-0A0	02	01	59	D1458-055-B00	10	05	42	SS-6151920-SP	12	06	54
B3138-051-000	02	01	19	NEEDLE		針		SS-6153040-SP	12	06	29
B3201-012-0A0	18	10	4					SS-6560150-SH	12	06	8
B3201-012-0B0	18	10	1	HDP-170B1800	06	03	62	SS-6560250-SH	12	06	5
B3204-012-0A0	18	10	13	NUT		ナット		SS-6580752-TP	08	04	30
B3212-012-000	18	10	18					SS-6621210-SP	02	01	6
B3214-012-0A0	18	10	11					SS-7081310-SN	18	10	20
B3217-012-000	18	10	19					SS-7090510-SP	16	08	24
B3223-012-0A0	18	10	7	NM-6050001-SP	08	04	5	SS-7090520-SP	02	01	20
B3228-012-000	18	10	16	NM-6050001-SP	08	04	8	SS-7090540-SP	14	07	39
B3229-012-000	18	10	14	NM-6050550-SP	08	04	3	SS-7090620-TP	06	03	12
B3301-012-000	17	09	22	NM-6061061-SE	17	09	9	SS-7090910-SP	10	05	6
B3301-051-0B0	17	09	1	NM-6100663-SE	17	09	19	SS-7090910-SP	10	05	17
B3302-012-000	17	09	12	NS-6060350-SP	02	01	49	SS-7110410-SN	18	10	15
B3303-012-0A0	17	09	18	NS-6080210-SP	08	04	39	SS-7110540-SP	16	08	7
B3303-372-0A0	17	09	13	NS-6080210-SP	14	07	4	SS-7110720-SP	02	01	69
B3305-012-000	17	09	10	NS-6110310-SP	10	05	26	SS-7110740-TP	08	04	13
B3306-012-000	17	09	7	NS-6110420-SP	12	06	22	SS-7110820-SN	18	10	5
B3307-521-000	17	09	5	NS-6110420-SP	12	06	27	SS-7111310-SP	10	05	13
B3308-012-000	17	09	6	NS-6110530-SP	14	07	27	SS-7111310-TP	06	03	30
B3309-012-000	17	09	4	NS-6123881-SE	17	09	17	SS-7111310-TP	08	04	47
B3310-012-000	17	09	2	NS-6150310-SP	16	08	16	SS-7111410-SP	14	07	48
B3311-012-000	17	09	11	NS-6160520-SP	08	04	21	SS-7150740-SP	02	01	8
B3312-012-000	17	09	8	NS-6620310-SP	02	01	21	SS-7150740-SP	18	10	25
B3409-053-000	16	08	1	NS-6620310-SP	08	04	25	SS-7151120-SP	04	02	9
B3410-051-000	16	08	4	NS-6660430-SP	10	05	30	SS-7151210-SP	14	07	37
B3413-521-000	16	08	5	NS-6700420-SP	08	04	56	SS-7151550-SP	16	08	22
B3414-051-000	16	08	8	PIN		ピン		SS-7151610-SP	16	08	34
B3419-122-000	16	08	29					SS-7161640-SP	10	05	35
B3420-521-000	16	08	30	PD-0231100-0B	16	08	3	SS-7620750-SP	14	07	63
B3424-521-000	16	08	17	PS-0200102-KH	12	06	46	SS-7661110-TH	04	02	60
B3425-521-000	16	08	14	PS-0400222-K0	06	03	49	SS-7681750-TP	04	02	17
B3426-521-000	16	08	13	PT-0201200-S0	10	05	11	SS-7681750-TP	04	02	34
B3427-521-0A0	16	08	25	PT-0301800-S0	06	03	29	SS-7762840-SP	12	06	30
B3427-521-000	16	08	32					SS-8080310-TP	06	03	52
B3428-521-000	16	08	23	SNAP RING		輪		SS-8080610-SP	06	03	54
B3429-521-000	16	08	20					SS-8080650-TP	06	03	61
B3430-521-000	16	08	21	RE-0500000-K0	14	07	9	SS-8080660-TP	06	03	27
B3430-552-0A0	16	08	26	RE-0700000-K0	06	03	36	SS-8080660-TP	06	03	57
B3431-521-0B0	16	08	12	HINGE SCREW		板ネジ		SS-8081050-TH	08	04	40
B3431-521-0C0	16	08	11					SS-8081050-TH	14	07	3
B3431-521-000	16	08	19	SD-0380551-SL	02	01	37	SS-8090410-SP	04	02	51
B3431-552-000-A	16	08	27	SD-0450211-SP	02	01	3	SS-8090410-TP	06	03	10
B3432-521-000	16	08	31	SD-0450401-SP	06	03	44	SS-8090530-TP	12	06	61
B3501-051-000	02	01	9	SD-0470281-SP	02	01	47	SS-8090710-SP	06	03	40
B3542-581-000	12	06	23	SD-0490261-SP	18	10	17	SS-8110510-SN	18	10	12
B8230-521-0A0	18	10	21	SD-0601171-SP	02	01	64	SS-8110510-SP	02	01	16
B8230-521-00A	18	10	22	SD-0630241-S0	02	01	14	SS-8110510-SP	14	07	13
B8230-521-00B	18	10	23	SD-0640322-TP	04	02	56	SS-8110520-TP	14	07	41
B8230-521-00C	18	10	26	SD-0640323-TP	14	07	58	SS-8110520-TP	14	07	32
B9117-563-000	12	06	10	SD-0790361-SP	16	08	2	SS-8110750-SP	06	03	46
											32

From the library of: Diamond Needle Corp

NUMERICAL INDEX OF PARTS

索引

Part No. 品番	Page 頁	Item 項目	Ref. No.	Part No. 品番	Page 頁	Item 項目	Ref. No.	Part No. 品番	Page 頁	Item 項目	Ref. No.
SS-8110750-SP	14	07	14								
SS-8110750-SP	14	07	31								
SS-8110750-SP	14	07	35								
SS-8110750-SP	14	07	43								
SS-8111251-SP	02	01	67								
SS-8111610-SP	06	03	35								
SS-8150410-SP	08	04	51								
SS-8150580-SP	12	06	43								
SS-8150710-SP	04	02	43								
SS-8150710-SP	12	06	33								
SS-8150710-SP	14	07	23								
SS-8150750-SP	12	06	62								
SS-8151150-SP	04	02	24								
SS-8151150-SP	04	02	46								
SS-8151150-SP	08	04	49								
SS-8151150-SP	10	05	2								
SS-8151150-SP	10	05	4								
SS-8151150-SP	12	06	34								
SS-8151150-SP	14	07	56								
SS-8151230-SP	04	02	30								
SS-8151230-SP	12	06	18								
SS-8151280-SP	14	07	55								
SS-8151280-SP	14	07	62								
SS-8151770-SP	14	07	6								
SS-8151780-SP	04	02	38								
SS-8151780-SP	12	06	50								
SS-8151780-SP	14	07	5								
SS-8152030-SP	04	02	37								
SS-8152030-SP	08	04	53								
SS-8152030-SP	12	06	26								
SS-8152030-SP	12	06	63								
SS-8152080-SP	12	06	51								
SS-8153010-SP	16	08	15								
SS-8620610-SP	08	04	36								
SS-8660530-SP	12	06	38								
SS-8660530-TP	04	02	27								
SS-8660670-SP	12	06	39								
SS-8660830-TP	12	06	41								
SS-8660970-TP	04	02	28								
SS-8660970-TP	14	07	68								
SS-8680540-SP	04	02	14								
SS-8680730-SP	04	02	15								
SS-8681650-TP	04	02	16								
SS-8681650-TP	04	02	33								
SS-9111010-SP	02	01	24								
SS-9111820-SP	14	07	28								
SS-9121340-CP	14	07	29								
SS-9151440-CP	08	04	34								
SS-9151540-SP	16	08	18								
SS-9151630-CP	14	07	50								
SS-9182010-SN	16	08	33								
SS-9660940-SP	14	07	67								
SS-9661120-CP	16	08	28								
PLUG		止x栓									
TA-0290301-H0	04	02	4								
WASHER		垫金									
WP-0371016-SD	12	06	12								
WP-0450801-SD	02	01	61								
WP-0480856-SP	02	01	23								
WP-0480856-SP	06	03	43								
WP-0480856-SP	14	07	30								
WP-0501016-SC	18	10	3								
WP-0501016-SC	18	10	6								
WP-0501016-SC	18	10	28								
WP-0560860-SE	17	09	15								
WP-0650876-SD	18	10	24								
WP-0651056-SD	10	05	8								
WP-0753016-SZ	12	06	31								
WS-0531060-KR	17	09	16								
WS-0641560-KR	17	09	3								
WS-0651510-KP	08	04	35								
WS-1002560-KR	17	09	21								
WZ-0520550-KF	02	01	2								

From the library of: Diamond Needle Corp